

**TECHNICAL MANUAL**

**OPERATOR, ORGANIZATIONAL, DIRECT  
SUPPORT, AND GENERAL SUPPORT  
MAINTENANCE MANUAL**

**FOR**

**CONVERTER,  
TELEPHONE SIGNAL**

**CV-1919/G**

**NSN 5805-00-910-8848**

---

**HEADQUARTERS, DEPARTMENT OF THE ARMY**

**October 1976**



TECHNICAL MANUAL }  
 No. TM 11-5805-689-14 }

HEADQUARTERS  
 DEPARTMENT OF THE ARMY  
 WASHINGTON, DC 4 October 1976

**OPERATOR, ORGANIZATIONAL, DIRECT  
 SUPPORT, AND GENERAL SUPPORT MAINTENANCE MANUAL  
 CONVERTER, TELEPHONE SIGNAL**

**CV-1919/G**

**NSN 5805-00-910-8848**

	Paragraph	Page
<b>CHAPTER I.</b> INTRODUCTION		
scope . . . . .	1	101
Purpose and Use . . . . .	2.0	1-1
Technics. Characteristics . . . . .	2.1	1-2
Additional Equipment Required	2.2	1-2
Description . . . . .	2.3	1-2
<b>II.</b> INSTALLATION		
Installing Batteries . . . . .	3.0	2-1
Preinstallation Check . . . . .	4.0	2-1
Installation for Switchboard Operators . . . . .	5.0	2-2
Installation Check . . . . .	6.0	2-2
Operating Procedures . . . . .	7.0	2-3
<b>III.</b> THEORY AND OPERATION		
Circuit Description. . . . .	8.0	3-1
Incoming Call . . . . .	9.0	3-3
Detailed Circuit Description.. . . . .	10.0	3-3
<b>IV.</b> MAINTENANCE		
Scope . . . . .	11.0	4-1
Troubleshooting Chart . . . . .	12.0	4-2
Common Module Removal and Keysender Adjustment Information	13.0	4-2
<b>APPENDIX A.</b> REFERENCES . . . . .	A-1	
<b>APPENDIX B.</b> MAINTENANCE ALLOCATION		
<b>Section I.</b> Introduction . . . . .	B-1	
<b>Section II.</b> Maintenance Allocation Chart. . . . .	B-2	

**LIST OF ILLUSTRATIONS**

Figure No.	Title	Page
Figure 1	Converter, Telephone Signal CV-1919/G	1-4
Figure 2	Converter, Telephone Signal CV-1919/G, Front Cover Removed	1-5
Figure 3	Converter, Telephone Signal CV-1919/G, Viewed from Rear, Dust Cover Removed	1-6
Figure 4	Converter, Telephone Signal CV-1919/G, Block Diagram	3-2
Figure 5	Converter, Telephone Signal CV-1919/G, Schematic Diagram	3-7
Figure 6	Converter, Telephone Signal CV-1919/G, Release Sequence Functional Block Diagram	3-8
Figure 7	Converter, Telephone Signal CV-1919/G, Channel Module (CN-1667) (Circuitry Exposed)	4-5
Figure 8	Converter, Telephone Signal CV-1919/G, Common Module (CN-1668) (Circuitry Exposed)	4-6
Figure 9	Converter, Telephone Signal CV-1919/G, Common Circuit Module (CN-1668) PWB Circuitry Exposed	4-7
Figure 10	Converter, Telephone Signal CV-1919/G, Common Circuit PWB Assembly (CN-1638)	4-8
Figure 11	Converter, Telephone Signal CV-1919/G, Channel PWB Assembly (CN-1643)	4-9
Figure 12	Thick Film Network Schematics (RA1-RA12)	4-10
Figure 13	DTMF Oscillator PWB Assembly (common module)	4-11
Figure 14	RELEASE Switch, S2 (common module)	4-12
Figure 15	Lightning Arrestor	4-13
Figure 16	POWEER ON-OFF Switch, S4 (common module)	4-14
Figure 17	Telephone Jack (J1, J2)	4-14
Figure 18	SEIZE switch, S1 (common module) and ACCESS switch, S1 (channel moduel)	4-15

## CHAPTER I INTRODUCTION

---

### 1.0. scope

This maintenance manual describes Converter, Telephone Signal CV-1919/G (hereinafter referred to as the Converter) and covers its operation, theory of operation, and organizational maintenance. The references to the "automatic switching center" within this manual apply to one switching center in particular, the AN/TTC-25. References to a "manual switchboard" apply to both the SB-22 ( )/PT and the SB-86 ( )/P. By this means, technically accurate examples rather than theoretical applications are provided for the user of this manual.

### 1.1. Indexes of Publications

a. Refer to the latest issue of DA Pam 310-4 to determine whether there are new editions, changes, or additional publications pertaining to the equipment.

b. Refer to the latest issue of DA Pam 310-7 to determine whether there are modification work orders (MWO's) pertaining to the system.

### 1.2. Forms and Records

a. *Reports of Maintenance and Unsatisfactory Equipment.* Maintenance forms, records, and reports which are to be used by maintenance personnel at all maintenance levels are listed in and prescribed by TM 38-750.

b. *Report of Packaging and Handling Deficiencies.* Fill out and forward DD Form 6 (Packaging Improvement Report as prescribed in AR 700-58/NAVSUPINST 4030.29/AFR 71-13/MCO P4030.29A, and DSAR 4145.8.

c. *Discrepancy in Shipment Report (DISREP) (SF 361).* Fill out and forward Discrepancy in Shipment Report (DISREP) (SF 361) as prescribed in AR 05-38/NAVSUPINST 4610.33A/AFR 75-18/MCO P4610.19B, and DSAR 4500.15.

### 1.3. Reporting of Errors

Report of *errors*, omissions, and recommendations for improving this publication is authorized and encouraged. Reports should be submitted on DA Form 2028 (Recommended Changes to Publications and Blank Forms) direct to Commander, US Army Electronics Command, ATTN: DRSEL-MA-Q Fort Monmouth, NJ 07703.

### 1.4. Administrative Storage

For procedures, forms and records, and inspections required during administrative storage of this equipment, refer to TM 740-90-1.

### 1.5. Destruction of Army Materiel

Demolition and destruction of electronic equipment will be under the direction of the commander and in accordance with TM 750-244-2.

### 2.0. Purpose and Use

The Converter is a three-channel transistorized, ruggedized, telephone signal converter designed for the Seventh Army Tactical Switching System (SATSS). The Converter is designed for rugged field service and is contained in a shock resistant waterproof case, constructed to prevent damage from dropping or improper handling. The Converter is a self-contained electronic unit which utilizes four D-size battery cells (mounted internally) for power. A carrying strap is provided as an integral part of the Converter for easy transportability in the field. The Converter weighs approximately 27 pounds and can be stack mounted with Manual Switchboard SB-22( )/PT and/or Manual Switchboard SB-86( )/P. The AC signaling circuitry provides comparability with the AN/TTC-25, and AN/TTC-37, and the SB-22( )/PT, or the SB-86( )/P. The Converter is designed to operate with the following equipments:

- a. Central Office, Telephone, Electronic AN/TT-C-25 and AN/TTC-37
- b. Cable, Telephone WM-13( )/U
- c. Central Office, Telephone, Manual AN/TTC-15( )
- d. Communications Central AN/TSC-41( )
- e. Switchboard, Telephone, Manual SB-22( )/PT
- f. Telephone Set TA-341/TT
- g. Switchboard, Manual SB-86()/PT
- h. Cable, Telephone WF-16/U
- i. Switchboard, Telephone, Cordless Manual SB - 3082-(V)1/GT. This Converter is designed to translate telephone signals between the automatic switching system and manual two-wire switchboards. The Converter is normally located at the manual two-wire switchboard and is normally connected to any truck selected for Converter termination at the AN/TTC-25 and/or AN/TTC-37 Central Office.

**2.1 Technical Characteristics**

2.1.1 Operating Battery Voltage	6.4 volts DC
2.1.2 Operating Voltage Limits	4.4 volts to 6.4 volts DC
2.1.3 Battery Life Operating	Minimum of 20 hrs. @ 0°F with a calling rate of 100 3-minute calls per 24 hour period
2.1.4 Number of Batteries Required	4
2.1.5 Type of Batteries Required:	
2.1.5.1 Artic Areas	BA-2030
2.1.5.2 All Other Areas	BA-30 (Standard D-size flashlight cell)
2.1.6 Number of Channels	3
2.1.7 Frequency Range	300 to 3500 Hz
2.1.8 Insertion Loss	Less than 5 dB
2.1.9 Channel Cross Talk	Less than -50 dB
2.1.10 Four-wire Impedance	600 ohms ±10%
2.1.11 Harmonic Distortion	Maximum of 300 dB below a fundamental within the frequency range of 300 to 3500 Hz transmitted at zero dBm Level
2.1.12 Noise Level	23 dBa or Less
2.1.13 Signaling (Input)	-2 dBm Maximum
2.1.14 Signaling (Output)	-14 dBm ±2 dB
2.1.15 Receiving Sensitivity	Must accept -25 dBm signals
2.1.16 Hybrid Transhybrid Loss	Shall not exceed 30 dB with two-wire port terminated in a 600 resistive load
2.1.17 Longitudinal Balance	At least 40 dB
2.1.18 Digit Frequencies (Hz)	
1	697/1209
2	697/1336
3	697/1477
4	770/1209
5	770/1336
6	770/1477
7	852/1209
8	852/1336
9	852/1477
0	941/1336
R	941/1209
C	941/1477
2.1.19 Supervisory Frequencies (Hz)	
Release	2600
Seize	2250
Ringback	425 interrupted at 2 seconds on, 4 seconds off
Busy	425 interrupted 1/2 second on, 1/2 second off. Switchboard originated
Test Tone	1050—Switchboard originated
2.1.20 Operating Temperature	-25°F to +125°F
2.1.21 Storage Temperature	-65°F to +155°F
2.1.22 Operating Elevation	Up to 10,000 feet above sea level
2.1.23 Non-operating Elevation	Up to 50,000 feet above sea level

**2.2 Additional Equipments Required**

2.2.1 Four Standard D-size flashlight cells	BA 30 or equivalent
2.2.2 For Cold Temperature Operation	Arctic cells BA-2030 or equivalent

**2.3 Description**

2.3.1 Converter, Telephone Signal CV-1919/G is similar in size and shape to the SB-22( )/PT Telephone Switchboard and is designed to be stackable with this unit (see Figure 1). The Converter is a self contained unit measuring approximately seven inches high, twelve inches deep

and eighteen inches wide. The Converter weighs approximately twenty-seven pounds.

2.3.2 The Converter is equipped with a watertight front cover, a canvas carrying strap for easy transportability, and a back cover designed to function as a dust cover. The back cover provides an opening (fitted with a rubber grommet), through which the

field wires are inserted. The unit can be operated with or without the back cover. The front cover must be removed to gain access to the front control panel. (See Figures 1 and 2.)

2.3.3 Figure 2 is a photograph of the front control panel of the Converter with the front cover removed. The common module contains the keysender, DTM - F, and seize oscillator circuitry, the night alarm (audible), the night alarm on-off switch and volume control, the seize and release pushbutton switches, the power on-off switch, the battery enclosure, and the common circuit printed wiring board (PWB) assembly. The other three modules are individual channel modules and are identical in circuit operation. All channel modules are interchangeable. The module closest to the common module is designated as Channel 1, the center module Channel 2 and the end module Channel 3. Each channel module contains the service request indicator (SRI), an access switch, two parallel wired telephone jacks, and a channel PWB assembly. A defective channel module can be removed for servicing while the Converter is in use without impairing the operation of the other two channels. For proper removal and replacement procedures, refer to the maintenance section of this manual.

2.3.4 The battery compartment allows for easy accessibility to the batteries from the front panel. For proper removal and replacement procedures, refer to the maintenance section of this manual.

2.3.5 The front panel of the Converter is constructed of aluminum and has a gray semi-gloss finish. The combination case is constructed of steel.

2.3.6 With the back cover removed, field terminations are accessible and the instruction plate is visible (see Figure 3). Basic operating and connection instructions are contained on the instruction plate. For detailed operating instructions, refer to the operating procedures in this manual. The field terminations are identified as the converter send and converter receive pairs and by the associated channel of the Converter to which they are connected. A positive and negative battery terminal at the back of the Converter allows the user to check battery voltage or to use an external power supply (with the batteries removed) for maintenance of the Converter at the depot. The additional terminal on the back of the Converter is for earth ground.

2.3.7 The housing protruding from the Converter back contains lightning arrestors for each field termination. The case of the Converter can be grounded to earth ground by running a strap from the terminal labeled EARTH GROUND (on the back of the Converter) to an earth grounding stake. Field operation requires this path to earth ground for the lightning arrestors. The internal circuitry is isolated from the Converter case (floating ground) to prevent interference between the two grounds.

2.3.8 The assembled unit is waterproof, airtight, and shock resistant, and has been subjected to severe testing at the factory before shipment to the field.

2.3.9 The Converter operates in conjunction with either the SB-22 (O)/PT or SB-86(O)/P. Connection between the Converter and either of these two units can be made by plugging either the answer cord from one of the manual switchboards or the cord from the operators' cord circuit into either jack on the front panel of the particular channel being utilized.

2.3.10 An audible alarm is provided to alert the operator of an incoming call.

2.3.11 A volume control and an on-off switch (which is an integral part of the volume control) is provided on the front panel to allow control of the volume of the night alarm signal, and to turn the night alarm off or on at the operator's discretion.

2.3.12 The service request indicator, flag type, provides a visual indication of a request-for-service on a particular channel. The flags on the indicator are coated with a phosphorescent material to allow the indicator to be seen at night without the aid of a light.

2.3.13 A power on-off switch allows the operator to disconnect the batteries from the internal circuitry when the Converter is not in use. The power ON-OFF switch is a locking, bat-handle switch designed to prevent the operator from accidentally bumping the switch to the OFF position during the operation of the Converter. Refer to the operational procedures section of this manual for normal operation of the bat-handle on-off switch.

#### NOTE

For access to the lightning arrestors and for removal of the modules, refer to the maintenance section of this manual.

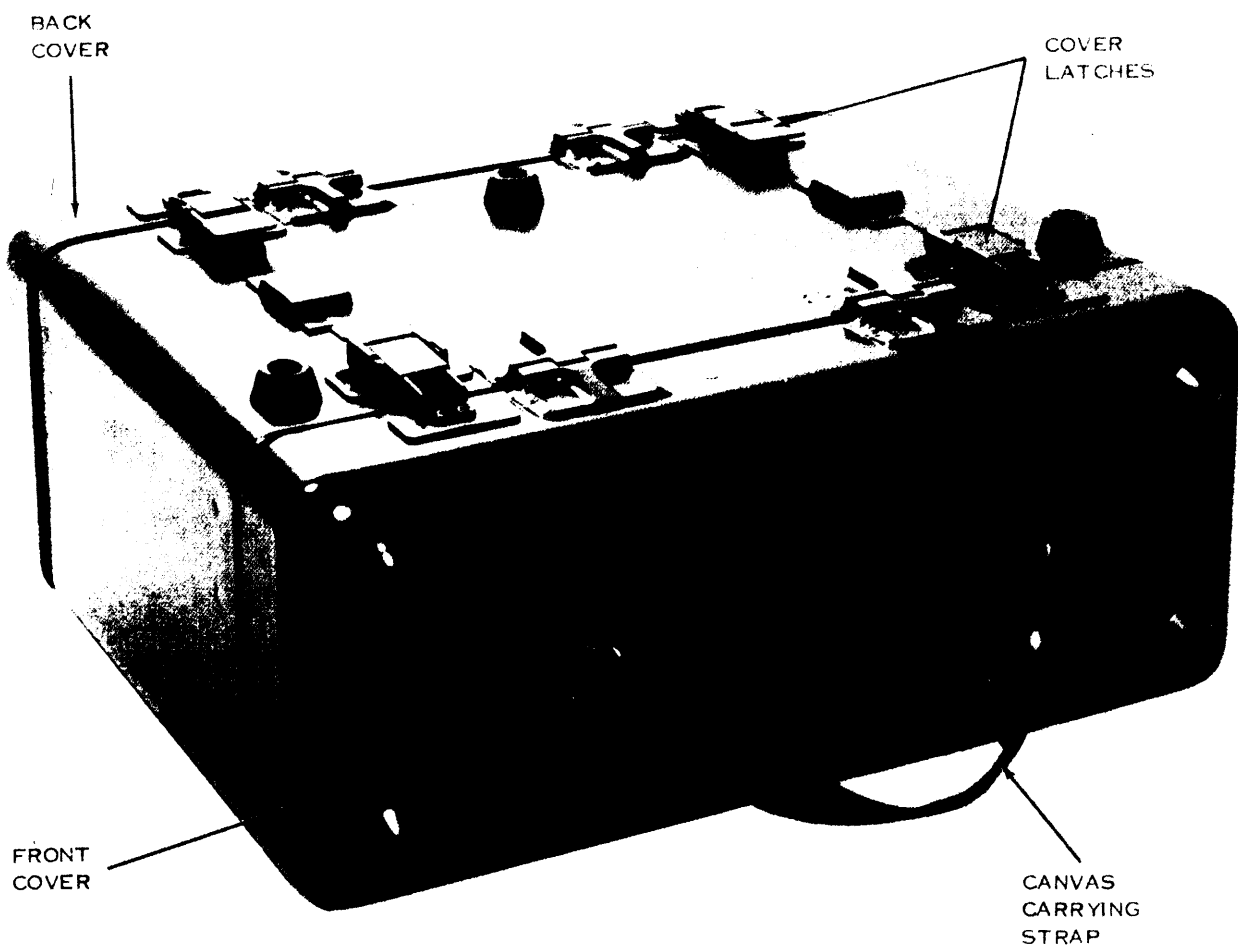

EL20B001

Figurer 1. Converter, telephone signal CV-1919/G.



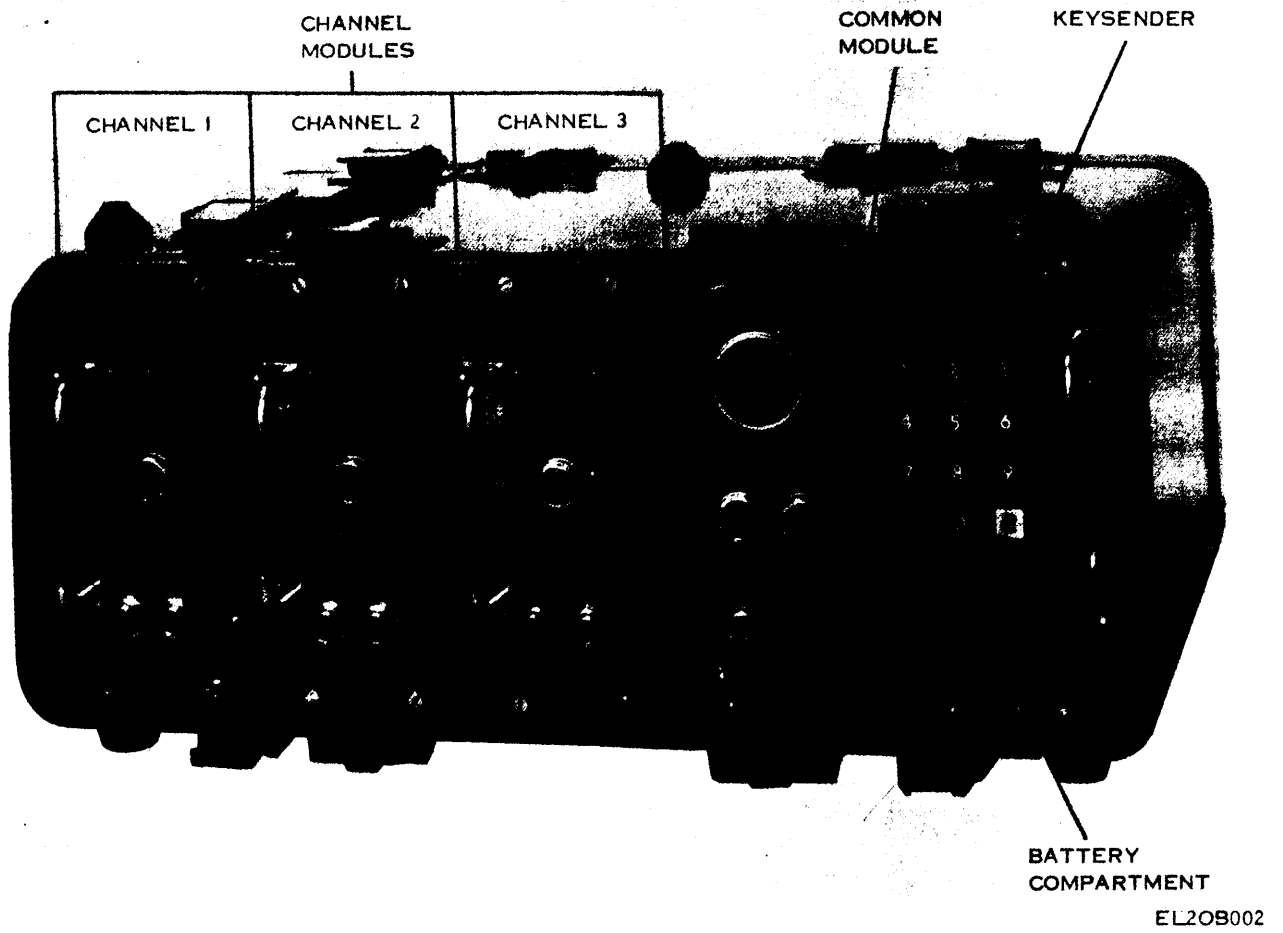
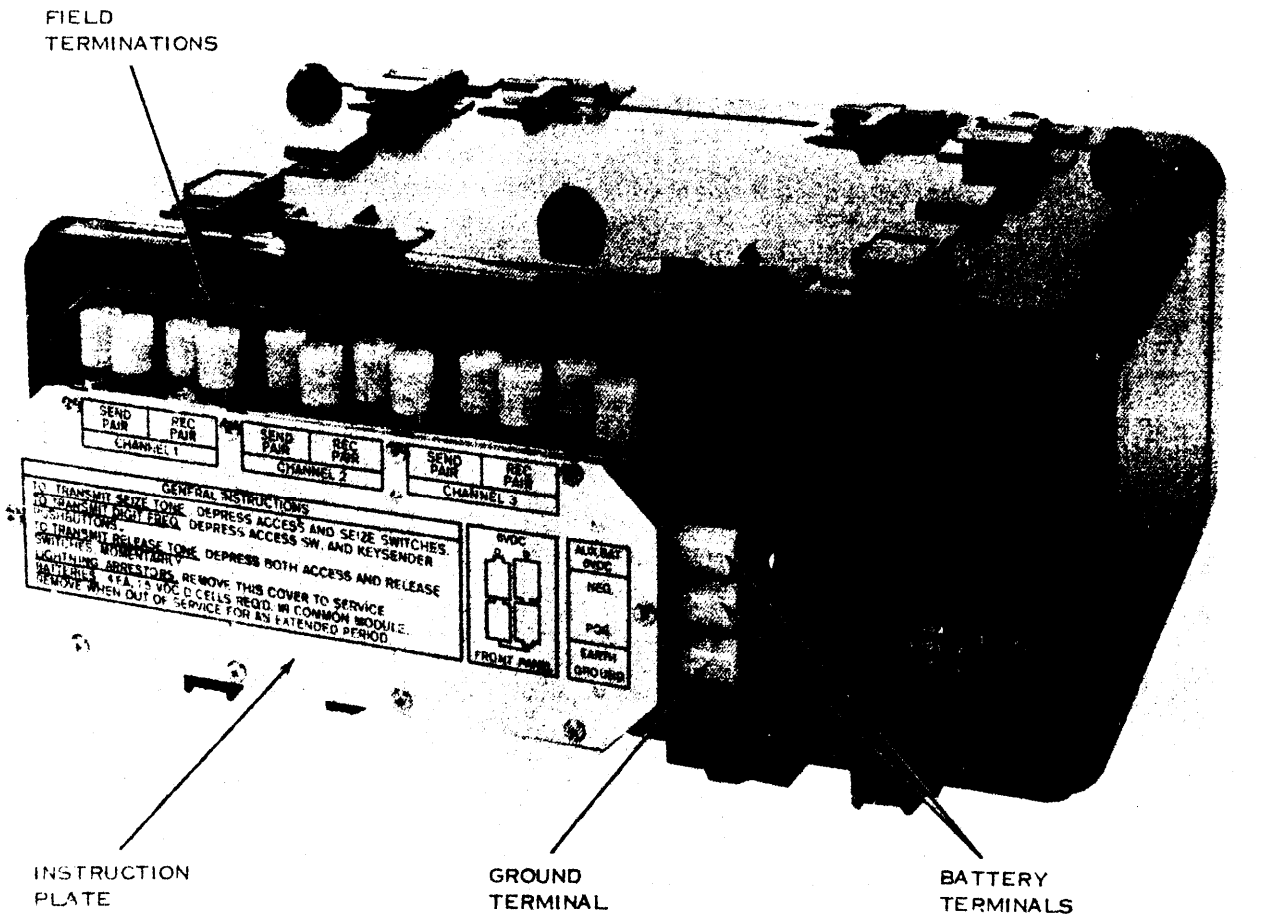

Figure 2. Converter, telephone signal CV-1919/G, front cover removed.



EL20B003

Figure 3. Converter, telephone signal CV-1919/G, cover removed, rear view

## CHAPTER II INSTALLATION

---

### 3.0. Installing Batteries

Batteries for the Converter are not shipped with the equipment. Batteries can be installed at a depot or at the operational site. Install the batteries as described below:

#### NOTE

Only Operational Converters should be equipped with batteries. Before installing batteries, check to insure the power on-off switch is in the OFF position.

3.1 Use fresh batteries which show no signs of leakage.

3.2 Locate the battery compartment on the front panel of the common module (see Figure 2).

3.3 Turn the knob counter clockwise until the cover can be pulled out from the front of the panel.

3.4 Insert four (4) D-size flashlight battery cells into the battery compartment; align polarities in accordance with the diagram on the instruction plate located on the back of the Converter (see Figure 3).

3.5 Thread the shaft (protruding from the battery cover) between the two rows of batteries and tighten into place by turning the knob clockwise until tight.

#### NOTE

Batteries will not make contact with the circuitry if batteries are inserted improperly. If Converter does not operate, check battery installation for proper polarization.

3.6 To remove the batteries, turn the knob counter clockwise until the front battery cover is free and pull out. (An extractor is attached to the front cover via the separation shaft.) The batteries will be extracted when the shaft is pulled out.

### 4.0. Preinstallation Check

After the batteries have been installed in the Converter (refer to paragraph 3.0), perform the following preinstallation check. This check can be performed in the field

4.1 Set the power on-off switch to the ON position by pulling out the bat-handle and moving to the ON position.

4.2 Check the condition of the service request indicators (SRI). If an indicator flag is visible, depress the access switch for that particular channel.

#### NOTE

If the night alarm switch is in the ON position, the night alarm may be activated (audible) when power is first turned on. Momentarily depress access pushbuttons of

each channel to clear both the SRI and night alarm. All three SRI's will have to be cleared before the night alarm will be silenced. If audible alarm is to be silenced when power is applied, turn the volume control on-off switch (on the front panel of the common module) to the OFF position before setting the power on-off switch to the ON position.

4.3 Attach a pair of wires from the send pair binding posts for channel 1 to the receive pair binding posts for channel 2. Connect a second pair of wires from the send pair binding posts for channel 2 of the receive pair binding posts for channel 3.

4.4 Insert the operators' answer cord into one of the channel 2 jacks.

4.5 Hold the channel 1 ACCESS pushbutton depressed and depress slowly and firmly each digit key on the keysender. Digit tones will be heard in the headset when each digit key is depressed. Repeat the above steps for each channel by inserting the answer cord into the appropriate channel jack. Release the ACCESS pushbutton when finished.

4.6 Insert the operators' answer cord into the jack for channel 2.

4.7 Insert a cord from the manual switchboard (SB-22-0/PT or SB-86(0)/P) into one of the channel 1 jacks.

4.8 Set the night alarm switch for maximum volume (MAX).

4.9 Depress and hold the ACCESS pushbutton for channel 1 while depressing the SEIZE pushbutton (located on the common module front panel). The following events take place:

a. A 2250 Hz seize tone should be heard in the headset .

b. The night alarm will be activated and the SRI for channel 2 will indicate a request-for-service.

c. Release the ACCESS and Seize pushbuttons.

d. The 2250 Hz tone is extinguished.

e. The night alarm and SRI remain activated for channel 2.

4.10 Depress the ACCESS and SEIZE pushbutton for channel 2.

a. The SRI for channel 2 returns to normal (no flag).

b. The SRI lamp for channel 3 indicates a request-for-service.

c. The night alarm comes on.

4.11 Depress the ACCESS pushbutton for channel 1

and the RELEASE pushbutton simultaneously but momentarily.

a. A 2600 Hz release tone is heard in the headset for 3 to 10 seconds and then subsides.

b. The SRI is activated for channel 2.

c. The night alarm is activated. Depress the ACCESS pushbutton for channel 2 to clear the Converter.

4.12 Remove the answer cord from channel 2 and reinsert in one of the jacks for channel 3.

4.13 Depress and hold the ACCESS pushbutton for channel 1 and the SEIZE pushbutton. The following events take place:

a. The channel 2 SRI indicates a request-for-service.

b. The night alarm is activated.

c. A 570 Hz acknowledge tone is heard in the headset.

4.14 Release the ACCESS and SEIZE pushbuttons. The following events take place:

a. The SRI for channel 2 continues to indicate a request-for-service.

b. The night alarm remains on.

c. The 570 Hz acknowledge tone stops.

d. A 425 Hz ring-back tone is heard in the headset.

4.15 Restore the Converter to the idle state by depressing the ACCESS pushbuttons for channels 2 and 3.

a. The SRI returns to normal on all channels.

b. The night alarm is off.

c. No tones are heard in the headset.

**NOTE**

The above test procedures will prove helpful as a preliminary checkout. Each step can be performed from a different channel to check out the various functions of the overall Converter as well as the proper operation of each channel. Refer to the maintenance section of this manual if a malfunction occurs during checkout.

**5.0. Installation for Switchboard Operation**

Three sets of WF-16/U field wires extending from the automatic switching center to the Converter are connected to the binding posts for the Converter send and receive pairs of each channel (see Figure 2). Each set of wires is inserted through the grommet in the dust cover (dust cover removed). Check to insure the power on-off switch is in the OFF position. Attach the appropriate pair of wires to each send and receive pair binding posts (located at the back of the Converter). Stack the Converter on top of the SB-220/PT or the SB-860/P and secure by unthreading the strap (located on the inside of the Converter cover) and running the strap completely around the two units. Secure the Converter by

buckling into place. Secure the back dust cover into position. Set the power on-off switch to the ON position. (Refer to paragraph 2.3. ) The Converter is now ready for operation.

**6.0. Installation Check**

When the Converter is installed for switchboard operation, it must be checked for proper operation. The following procedures should be sufficient to assure the operator that the Converter is operating properly.

**6.1 Operational Test Line Check**

a. Turn the power on-off switch to the ON position.

**NOTE**

It maybe necessary to depress the ACCESS pushbutton of each channel to return the service request indicators and the night alarm to normal when power is initially turned on.

b. Insert the answer cord from the operators cord circuit (on the manual switchboard) into one of the channel 1 jacks located on the front panel of the Converter. (Either jack may be used, as they are wired for parallel operation. )

c. Depress the ACCESS pushbutton for channel 1 and the common SEIZE pushbutton (see Figure 2). Hold both pushbuttons depressed until a 570 Hz acknowledge signal is heard in the headset. This indicates the seize signal has been detected by the switching center and a 570 Hz acknowledge signal is being returned to the Converter.

d. Release the ACCESS and SEIZE pushbuttons and listen in the headset for dial tone.

e. When dial tone is received, depress and hold the ACCESS pushbutton. Then depress digit 9 on the keysender (see Figure 2).

f. Dial tone should be inhibited by the automatic switching center when the first digit 9 is received from the Converter. Listen for the absence of dial tone. Depress the second and third digit 9 sequentially. (Depress each digit key slowly and firmly to assure proper operation of the keyswitch.)

g. Listen in the headset for a test tone from the automatic switching center.

h. After receiving the test tone, depress the RELEASE pushbutton to clear the channel, as follows.

i. Depress the ACCESS pushbutton for channel 1 and the common RELEASE pushbutton (see Figure 2). Both pushbuttons should be depressed simultaneously and momentarily. A 2600 Hz release tone will thus be transmitted from the Converter to the automatic switching center.

j. Listen for the absence of the test tone and for the receipt of a 570 Hz acknowledge tone. Note that the SERVICE REQUEST indicator does not come

on when receiving a 570 Hz acknowledge tone.

k. The acknowledge tone will cause the Converter to stop sending the release tone and channel 1 will become idle.

1. Repeat steps through *k* above for the remaining two channels.

#### NOTE

Use the procedures outlined in paragraphs 6.1 and 6.2 above when checking the Converters for proper operation. If any malfunction is experienced during this checkout, refer to the maintenance section of this manual for proper troubleshooting procedures .

### 7.0 Operating Procedures

#### 7.1 Incoming Call From AN/TTC-25

a. SERVICE REQUEST indicator indicates request-for-service (flag indicator).

b. Night alarm is activated (unless turned off).

c. Operator plugs answer cord from operators cord circuit on SB-22( )/PT or SB-86( )/P into one of the jacks on the channel requesting service (channel X).

d. Operator depresses ACCESS pushbutton for channel X.

e. Operator challenges call to determine the two-wire subscriber desired.

f. Operator plugs cord from desired two-wire subscriber into the freejack on channel X.

g. Operator rings forward to two-wire subscriber utilizing ringer on SB-220/PT or SB-860/p.

h. When the call is established, operator can monitor or dropout by removing the answer cord from channel X.

#### 7.2 Release Procedure (Release From Four-Wire Subscriber)

a. The SERVICE REQUEST indicator is activated for the channel being released (channel X).

b. The night alarm is activated.

c. The operator plugs the answer cord from the SB-220/PT into the free jack on channel X, or operates the B-860/P cord circuit switch to TALK LIST.

d. The operator challenges the call to determine if it is a legitimate release request.

e. Operator depresses the ACCESS pushbutton momentarily.

f. operator unplugs answer cord and two-wire subscriber cord.

g. The channel is now idle.

#### 7.3 Outgoing Call From Converter to Four-Wire Subscriber

a. Two-wire subscriber rings into SB-22( )/PT or SB-860/P.

b. operator inserts answer cord from SB-220/pT or SB-860/P into a jack on a channel requesting service.

c. Operator plugs two-wire subscriber cord into jack on an idle channel.

d. Operator depresses and holds the ACCESS pushbutton and the SEIZE pushbutton.

e. Operator listens in headset for 570 Hz acknowledge signal.

f. After signal is heard, operator releases the ACCESS and the SEIZE pushbuttons and listens for dial tone.

g. After dial tone is heard, operator depresses and holds the ACCESS pushbutton while depressing the digit keys corresponding to the number of the four-wire party being called.

h. Dial tone is extinguished after first digit.

i. Ring-back tone is heard in headset after last digit is keyed (depressed).

j. Operator releases the ACCESS pushbutton.

k. After call is established, operator drops out by unplugging SB-22( )/PT answer cord from channel jack or operating SB-860/P cord circuit switch to normal (center).

#### 7.4 Release Procedure From Converter

a. Operator momentarily depresses the ACCESS pushbutton for channel being released and common RELEASE pushbutton.

b. Operator unplugs answer cord and two-wire subscriber cord. Channel is idle.



## CHAPTER III

### THEORY AND OPERATION

---

#### 8.0 Circuit Description

The CV-1919/G is a three-channel transistorized two/four-wire telephone signal converter designed to function in conjunction with the Tactical Automatic Switching (TAS) Network. The Converter has been designed to comply with the Electronics Command Technical Requirement SCL-4659C and associated amendments. Power for this Converter is provided by a battery of four "D" size energy cells (in series connection) to supply a nominal 6.4 volts with fresh cells and a minimum of 4.4 volts at cell life end. The Converter circuitry has been designed to provide a minimum of 20 hours continuous service (from installation of fresh cells to, their end of life) in an environment of 0°F temperature with a calling rate of 100 three-minute calls *per* 24 hour period when 50 percent of the calls require use of the keysender. The Converter is designed to interface telephone signals between an automatic analog four-wire central office, AN/TTC-25 and manual two-wire telephone switchboards, SB-86()/P and SB-22()/PT. This Converter is used in conjunction with the manual two-wire switchboard to interface any two-wire telephone connection made by plug and jack with any four-wire trunk connection between this Converter and a central office automatic switchboard AN/TTC-25. The CV-1919/G Converter contains three modular interfacing channels and common equipment to

provide tones to operate the central office automatic switchboard. Each channel is terminated through a four-wire trunk connection to the central office automatic switchboard. This Converter automatically accepts calls from the central office automatic switchboard and alerts the two-wire manual switchboard operator when a request-for-service has been made. The manual switchboard operator responds to the request-for-service by inserting a cord-plug from the manual switchboard into the jack of the channel displaying the request-for-service (flag) and then momentarily depresses the ACCESS pushbutton of that channel. These actions by the manual switchboard operator reset the SRI, stop signals being sent by the Converter at the central office automatic switchboard and opens the voice path between the manual switchboard operator and the central office. The two-wire connection is made by the manual switchboard operator inserting the cord-plug from the two-wire position on the manual switchboard which is being called or is requesting service to a four-wire trunk. With these provisions this Converter may interface three individual two-wire trunk connections to three four-wire trunk connections at any one time. The electronic processing of a call from the automatic switching center will be described in the following paragraphs. Functional block diagram is included for clarification (see Figure 4).

CV-1919 INCOMING CALL SEQUENCE FUNCTIONAL BLOCK DIAGRAM

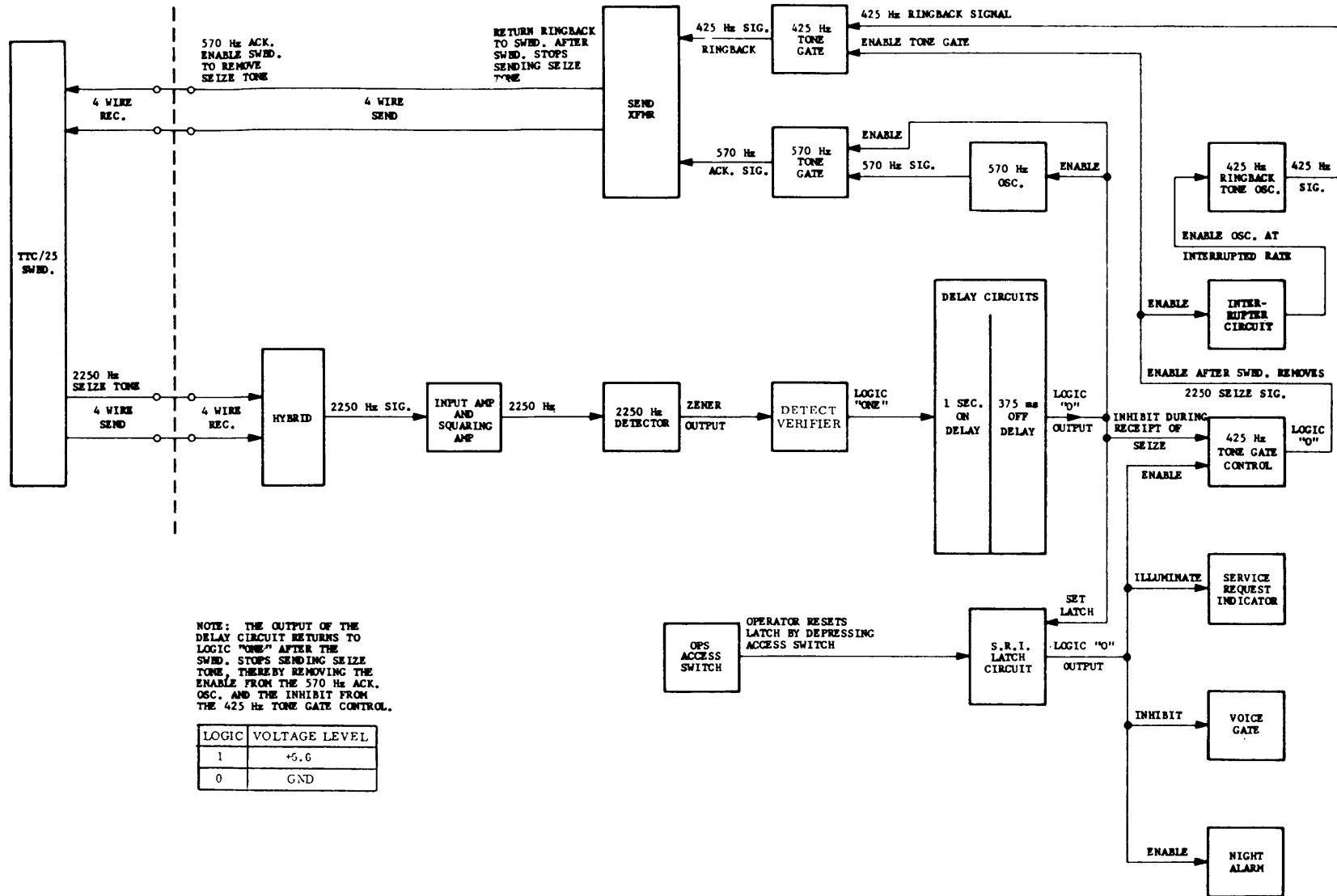

Figure 4. Telephone Signal Converter CV-1919/G, Block Diagram



## 9.0. Incoming Call

### 9.1 General

Reference the block diagram of Figure 4 for this description. The electronic processing of a call from the automatic switching center begins with a seize signal of 2250 Hz originating at the automatic switching center and appearing on the four-wire receive port of the Converter. The seize signal is inductively coupled to the input amplifier, amplified and coupled from the output stage of this amplifier to the input to the squaring amplifier. This amplifier accepts the sinusoidal signals from the input amplifier and produces a square wave output. In this case, the 2250 Hz seize signal is transformed into a square wave and coupled to the seize detector circuit. The signal is detected and coupled from the detector output to the turn-on delay circuit. This circuit changes the 2250 Hz signal into a DC potential or logic output. The turn-on delay circuit provides protection against false hits on the four-wire port from being recognized as legitimate signals. The turn on delay circuit is basically a transistor switching circuit controlled from the common Zener diode output of the detectors and an RC network in the collector of the first stage. The output of the turn-on delay circuit is coupled to the turn-off delay circuit. This is a transistor switching circuit designed to respond to the logic levels provided to it by the previous stages and is utilized to provide a turn-off delay which insures that a hit or momentary interruption of the seize signal on the four-wire receive port will not interrupt the call sequence. A logic output is obtained from the turn-off delay circuit and is coupled to the detector output stage. The detector output circuitry is a transistor switching circuit designed to function as a control for the latch circuitry and the tone gate circuitry. The logic 0 output obtained from the detector output circuit is coupled to the latch circuit as an enable condition and to the 425 Hz tone gate as an inhibit. The latch circuit output is coupled to the 570 Hz oscillator and enables the oscillator at this time. The latch circuit also activates the service request indicator for that particular channel indicating a request-for-service. The output of the 570 Hz oscillator is coupled to the 570 Hz tone gate and inductively coupled out on the four-wire send pair of the Converter to the automatic switching center. The automatic switching center then recognizes the 570 Hz signal from the Converter as a seize acknowledge signal and stops transmitting seize tone. The absence of seize tone at the Converter allows the detector circuitry to return to normal. This removes the inhibit signal from the 425 Hz tone gate. The latch circuit remains activated and a logic 1 output from the latch circuit enables the 425 Hz interrupter

which, in turn, enables the 425 Hz oscillator at a two second on, four second off rate. The 425 Hz ringback signal is coupled (via the 425 Hz tone signal output on the four-wire send pair) to the Converter and to the automatic switching center. The operator of the Converter recognizes the request-for-service and inserts the answer cord, from the operators cord circuit on the SB-22 or the SB-86 switchboard, into the appropriate channel jack. The operator then depresses the access switch which clears the service request indicator and talks to the four-wire subscriber to determine with whom the four-wire subscriber wishes to converse. The operator may extend the call from the SB-22, or the SB-86, switchboard to the two-wire subscriber in the normal manner. After connection to the two-wire subscriber is established, the operator plugs the two-wire subscribers answer cord into the appropriate channel and the voice path from the four-wire subscriber to the two-wire subscriber is complete. The switchboard operator can either monitor the call or remove the operators answer cord from the channel jack and wait for a release indication. When the call is terminated and a release signal is received from the automatic switching center (fig. 6) the sequence of events in the Converter (in response to the release signal) is identical to the sequence of events when receiving the 2250 Hz seize signal as explained above. The Converter transmits a 570 Hz acknowledge signal as explained above and the automatic switching center recognizes the signal as a release acknowledge signal and stops sending release to the Converter. The operator of the Converter recognizes the service request indicator as a service request and inserts the *answer cord* from the operators cord circuit into the free jack associated with the particular channel and challenges the call. The switchboard operator now depresses the ACCESS pushbutton and removes the cords from the Converter. The channel is now idle.

### 10.0. Detailed Circuit Description (figs. 5 and 12)

The electronic processing of a call from the automatic switchboard begins with a seize signal of 2250 Hz originating at the automatic switchboard and appearing on the four-wire receive port of transformer T2. This signal is coupled by mutual inductance through the transformer to appear across the series network of resistor R3, resistor R4 and capacitor C1. C2 and R5 makeup the hybrid balance compensating network. Capacitor C1 connects to a positive reference and is utilized as an RF bypass. Diode CR7 is utilized to protect transistor Q1 during receipt of a 90 volt rms, 20 Hz ring signal. The ring signal is coupled through resistor R2 to the base of transistor Q1 which forms the input terminal to the

input amplifier. Transistor Q1 is a grounded emitter voltage amplifier. The output from the collector of transistor Q1 is connected to the base of an emitter follower, transistor Q2. Transistor Q2 superimposes current gain on the voltage gain accomplished by transistor Q1. A portion of the output taken from the emitter of transistor Q2 is fed back through resistor R1 to the base of transistor Q1 to stabilize the AC voltage gain of this stage. Since the alternating current through resistor R1 is 180° out of phase with respect to the alternating current flowing through resistors R2 and R3, the AC voltage gain of this stage is described by the resistance ratio of resistors R2, R3, and R1. Since resistors R2 and R3 equal 20K resistance and resistor R1 equals 182K resistance, the approximate voltage gain from the signal induced across resistor R3 to the signal appearing at the emitter of transistor Q2 is equal to the resistance of resistor R1 over R2 and resistor R3, or 182K/20K, or 9.1. The loading effect of resistor R6 and capacitive reactance of capacitor C2 is considered as negligible across the dynamic resistance of the base-emitter junction of transistor Q1. A second portion of the signal appearing at the emitter of transistor Q2 is fed through resistor R8 to charge capacitor C2. Since the time constant formed by capacitor C2 looking into resistors R6 and R8 is long the voltage appearing across capacitor C2 will be essentially constant. The purpose of the feedback network formed by capacitor C2, and resistors R6 and R8, is to lower the average voltage measured across resistor R9. The design level for this voltage is 1.7 volts. If this value is too high or too low, premature clipping of the waveform appearing across resistor R9 will occur and adversely affect the bandpass characteristic of the 570 Hz, 2250 Hz, and 2600 Hz detector tank circuits. The remainder of the AC signal across resistor R9 is coupled by capacitor C3 to the base of transistor Q3. Transistor Q3 with no AC signal imposed on its base will be normally turned on. (The collector current of transistor Q3 will be equal to the current flowing through resistor R11 less the base current of transistor Q3 flowing through resistor R10 to resistor R20 to the positive power terminal.) The bases of transistors Q3 and Q4 both refer to a nominal 1.2 volts held at the collector of transistor Q5. This voltage represents the voltage drop across diode CR10 and the base-emitter forward voltage of transistor Q5. Q6 provides current from which this voltage is derived. Q6 also provides current for CR9. Resistors R16 and R17 make up a voltage divider across CR9. The junction of this voltage divider is tied to the base of Q4 whereas one end of R16, the 1.2V, is tied to Q3 (through R10). The arrangement assures that the squaring amplifiers Q3 and Q4 will always be in the proper

quiescent state and will not be subject to latch up. The output of the squaring amplifier is coupled from the collector of transistor Q4 to the base of detector transistors Q7 and Q8. The detector utilizing transistor Q8 is tuned for a resonant frequency of 2250 Hz by capacitor C5. The clipped portion of the detector tanks passes through either diode CR11 or diode CR12, through Zener diode CR13 to enter the base of transistor Q10. As the voltage across resistor R27 reaches the forward voltage of the base-emitter junction of transistor Q10 about 40 microampere will pass through resistor R27 and the remainder of the clipped current from the detector tank will pass through the base-emitter junction of transistor Q10. The product of this base current ( $I_{B10}$ ) and the current gain (HFE) of transistor Q10 will be conducted by the collector of transistor Q10 to discharge capacitor C7 through resistor R30. The remainder of the collector current ( $I_{C10}$ ) passes through resistor R28 to resistor R29 and the base of transistor Q12 and saturates its collector. The  $V_{cc} - V_{sat}$  of transistor Q12 appears at test point 5 (TP5). A portion of the collector current ( $I_{C12}$ ) passes through resistor R33 and the base of transistor Q13 to saturate its collector. As the detector tank voltage falls below the required value to cause diode CR13 to conduct, the voltage across resistor R27 falls below the required forward voltage to keep the base-emitter junction of transistor Q10 in conduction. The collector current ( $I_{C10}$ ), therefore, falls off and the current through R29 now serves to charge capacitor C7. The collector of transistor Q11 now draws current through resistor R31. This current maintains the voltage drop across resistor R28 to keep transistor Q12 turned on. The charging time constant of capacitor C7 is sufficiently long that transistor Q11 and, therefore, transistor Q12 will remain in conduction until the next positive going cycle of voltage across the detector tank reaches the voltage necessary to cause diode CR13 to conduct and again inject current into the base of transistor Q10. Capacitor C7 will then again discharge through the collector of transistor Q10 to repeat the cycle. The turn on delay circuit consists of transistors Q13, Q14, and Q15 along with capacitor C8, resistors R37, R33, R32, R36, and R39. The output of transistor Q12 is coupled through resistor R32 to the base of transistor Q14 and through resistor R33 to the base of transistor Q13 and resistor R34. The action of this circuit is as follows. During the receipt of a seize, or acknowledge signal the collector of transistor Q12 goes to a logic 1 condition. At this time, the current flow is through transistor Q12, through diode CR18, resistor R33 and resistor R34 to ground. Base current is thus supplied to transistor Q13 causing it to conduct. Capacitor C8 immediately

discharges through diode CR19 and transistor Q13 holding transistor Q15 off until the capacitor charges to the proper potential to turn transistor Q15 on. This time period is determined by the charge time of capacitor C8 through resistor R36 and is set at a nominal time of 1 second. When capacitor C8 charges to the proper value, transistor Q15 conducts. The collector of transistor Q15 switches to a logic 0 condition and is coupled directly to the emitter of transistor Q14. This causes transistor Q14 to conduct. The collector of transistor Q14 then switches from a logic 0 condition. The collector of transistor of Q14 switching to a logic 0 removes the base current from transistors Q16 and Q17 to switch transistor Q14 off. The collector of transistor Q14 switching to a logic 0 also attempts to turn off transistor Q17. However, before transistor Q17 can turn off, the capacitor C9 (between the collector of transistor Q16 and the base of Q17) has to discharge through resistor R43, transistor Q14 and transistor Q15 to ground. Thus Q17 stays in conduction for the time period established by the discharge of capacitor C9 and resistor R43. When capacitor C9 discharges, transistor Q17 turns off and changes the potential on the emitter of transistor Q17 from a logic 0 to a logic 1. The emitter of transistor Q17 is coupled directly to the base of transistor Q27. This switching off of transistor Q17 removes the necessary base current to keep transistor Q27 in conduction. The collector of transistor Q27 then switches from a logic 0 to a logic 1. The collector of transistor Q27 is coupled through diode CR44 to the base of transistor Q28. Transistor Q28 now starts conducting. The collector of transistor Q28 is coupled through resistor R78 to the base of latch circuit transistor Q31. This provides a path for the base current for transistor Q31 which causes Q31 to conduct. The collector of transistor Q31 is coupled through resistor R81 and to diode CR51 to the base latch transistor Q30. Transistor Q31 is a PNP transistor and the conduction of transistor Q31 causes the collector of this transistor to switch to a logic 1. This logic 1 is coupled to the base of transistor Q31 and causes it to conduct. The collector of transistor Q30 now holds transistor Q31 in conduction and the circuit is "latched up." The collector of transistor Q30 is coupled through diode CR49 and resistor R53 to the base of voice gate inhibit transistor Q19. This circuit will be explained later since it is not utilized until the operator inserts the plug into the jack. The collector of transistor Q30 is also coupled directly to the emitter of the 425 Hz tone gate control transistor Q29 and would enable this transistor to conduct at this time, but an inhibit is being held on its base by the output of the detector output transistor Q28 through diode CR46, resistor

R76 and diode CR47. The 425 Hz tone gate circuit will also be explained later as it does not come into play at this time. The collector of latch transistor Q30 is also coupled to the SRI and activates the indicator, indicating a request-for-service to the operator. (In this Converter, all the oscillators are off at all times with the exception of the seize/DTMF oscillator.) The function of the 570 Hz oscillator will be described at this time. To avoid repetition, only one of the oscillators will be explained since all oscillators are of the same basic design. The collector of the 570 Hz oscillator transistor Q104 is coupled through Q103 to positive battery potential. Base drive for transistor Q104 is derived through the oscillator transformer center tap. One side of the oscillator tank coil connects to the voltage divider network consisting of resistors R108 and R109. Capacitor C105 tunes the tank to a resonant frequency of 570 Hz. Initially, when power is turned on, transistor Q104 conducts. The DC current flow is from the positive voltage source through the transistor Q103 emitter to collector and Q104 collector to its emitter, through resistor R110, and through the oscillator transformer feedback winding to negative battery. Base current flows from the positive voltage source through resistor R109, through part of the tank coil winding, to the base of transistor Q104. When transistor Q104 starts conducting a voltage is built up across the feedback winding in the emitter circuit. A portion of this voltage is inductively coupled to the base via the tank circuit winding. As this signal is in phase with the signal on the emitter of transistor Q102, oscillations are initiated. Oscillations are sustained as long as power is applied to the circuit. Diodes CR109 and CR110 form a clipping network across the tank circuit which keeps the AC swing constant at the base of transistor Q104 due to the saturation of the diodes on the peak of the AC swing. Therefore, the AC voltage remains essentially constant on the emitter of transistor Q104. The output is taken from the emitter of transistor Q104 thus minimizing the loading effect produced by the tone gate circuit. Coupling capacitor C107 couples the 570 Hz signal to the base of tone gate transistor Q25. The tone gate transistor is enabled at this time because the collector of the detector output transistor Q28 is providing bias to the emitter of transistor Q25 through resistor R67. The 570 Hz tone gate is a one-stage gate designed to provide a loss, together with the inherent loss of output transformer T1 of approximately 11 dB (with respect to the signal on the base of transistor Q25). The collector of transistor Q25 is directly coupled to transformer T1. Thus the 570 Hz signal appears on the four-wire send pair at  $-14 \text{ dBm} \pm 2 \text{ dB}$  as per specification. When the

automatic switching center receives the 570 Hz seize acknowledge signal from the Converter, the 2250 Hz signal being transmitted from the automatic switching center causes the transistors in the turn on delay circuit to return to their normal state. The action of the turn off delay circuit is as follows: When transistor Q14 return to normal (switches off), base drive is provided to transistor Q16, in the turn off delay circuit through resistors R39, R40, and diode CR22. Transistor Q16 switches on causing its collector to go to a logic 0. The logic 0 is coupled to capacitor C9, Initially all the current flow is from the positive voltage source through resistors R39 and R43, through capacitor C9, diode CR23 and transistor Q16, to negative battery. This holds transistor Q17 off and no change is seen at the collector of the detector output transistor Q28. Capacitor C9 now charges through resistors R43 and R39 and base drive is provided for transistor Q17 after a delay which is established by the time constant of capacitor C9, resistors R43 and R39. When transistor Q17 starts conducting, transistor Q28 turns off, thus a turn off delay of a nominal 450 milliseconds is provided per specification. The action of transistor Q28 switching off removes the enable from the 570 Hz tone gate and 570 Hz osc. This inhibits the sending of 570 Hz signal to the automatic switching center switchboard. The 425 Hz tone gate circuit is now enabled. This is because the latch transistor Q30 is still conducting and the logic 0 has been removed from diode CR46 in the base circuit of the 425 Hz tone gate control circuit Q29. The 425 Hz signal generated by the Converter is the ring-back signal. This ring-back signal is on for two seconds and off for four seconds, and is controlled by the interrupter circuit to be explained next. The interrupter circuit is a monostable multivibrator which is on for two seconds and off for four seconds. This circuit consists of two transistors Q105 and Q106, resistors R111, R112, R113, R114 and R115, diodes CR111, CR112, CR113 and CR114, and capacitors C108 and C109. This circuit is controlled by each individual channel through diodes CR120, CR121, and CR122, from PNP latch transistor Q31. When power is applied, transistor Q106 conducts and the collector goes to a logic 0. This logic 0 is coupled to the base of transistor Q105 through capacitor C109 holding transistor Q105 off. capacitor C109 charges up through resistor R113. When the capacitor charges up to the proper positive voltage, transistor Q105 turns on. The collector of transistor Q105 goes to a logic 0 and is then coupled through capacitor C108 to the base of transistor Q106. This turns transistor Q106 off until capacitor C108 charges up through resistor R111. The collector of transistor Q106 goes to a logic 0 for two seconds

and to a logic 1 for four seconds. The collector is DC coupled through resistor R115 and diode CR113 to the base of the 425 Hz oscillator controlled transistor Q107. Therefore, the 425 Hz oscillator is on for two seconds and is off for four seconds. The output of the 425 Hz oscillator is taken from the emitter of transistor Q108 and coupled to the base of tone gate transistor Q24. The 425 Hz ring-back signal is now inductively coupled from the primary of the output transformer T1 out on the four-wire send to the automatic switching center switchboard as ring-back tone. When the operator services the call, the ACCESS pushbutton is depressed to clear the latch which inhibits the ring-back tone. Momentary depression of the ACCESS pushbutton applies a ground through diode CR50 which clears the latch and inhibits the ring-back tone. The operation of the 3 to 10 second release timer will be described later along with the presentation of a functional block diagram (see Figure 6). Depression of the ACCESS pushbutton S1 and momentary depression of the RELEASE pushbutton (S2 on common module) by the operator activates the 2600 Hz oscillator and activates the release timer. The action of the release timer is as follows: Depression of the RELEASE pushbutton changes the potential on resistor R52 to a positive voltage. As long as the RELEASE pushbutton is held depressed, nothing happens in the timer circuit. When the operator releases the pushbutton, the potential on resistor R54 changes to negative battery. Current now flows from +V through resistor R56, capacitor C13, and resistor R54 to negative battery. The potential at the base of transistor Q20 switches from approximately 0.7 volt positive to 4 volts negative. Transistor Q20 which is normally conducting, now switches off causing its collector to go to approximately 2 volts positive. This provides base current to transistor Q21. Transistor Q21 switches on and provides base drive to transistor Q22. The collector of transistor Q22 then switches to a logic 0. This condition is maintained until capacitor C13 charges up through resistor R56 to a voltage sufficient to cause transistor Q20 to conduct (0.7 volts positive). The logic 0 at the collector of transistor Q22 is coupled through diode CR16 to capacitor C6. This tunes the 2250 Hz detector to 570 Hz to enable receipt of the 570 Hz acknowledge signal. The logic 0 is also coupled to the 570 Hz gate transistor base through diode CR17, providing base drive for transistor Q9. The resultant positive potential at the collector of transistor Q9 provides the proper bias condition for the 570 Hz driver transistor Q8. The logic 0 at the collector of transistor Q22 is also coupled through CR103 to the 2600 Hz tone gate Q23 to enable this circuit. The 2600 Hz oscillator transistor Q102 is connected

through capacitor C104 to the base of 2600 Hz tone gate transistor Q23, and is inductively coupled to the four-wire send pair via send transformer T1 to the automatic switching center. The collector of release timer transistor Q22 is also coupled through diode CR39 to inhibit the voice circuit during the release sequence. If the automatic switching center recognizes release tone and returns 570 Hz release acknowledge to the Converter, the action of the Converter circuitry is identical to that explained for the 2250 Hz seize tone except that when the collector of transistor Q12 (turn on delay transistor) switches to logic 1 it is coupled through resistor R55 to the base of transistor Q20. This essentially parallels resistor R56 and reduces the time constant of capacitor C13 and resistor R56 to a nominal 1 second which causes the timer to switch off after one second, thus adhering to the specification of sending a minimum of 800 milliseconds of release tone.

The voice gate circuit is a one stage amplifier designed as a combination of a common base and a grounded emitter configuration. The base circuit is not entirely AC bypassed due to the action of resistor R47 which is used as a gain control. A signal coming in on the two-wire port is coupled through capacitor C11 to the base of transistor Q18. The dynamic impedance of the transistor in this configuration, when conducting, is approximately a 600 ohm termination across hybrid transformer T1. Transistor Q19 is utilized to inhibit transistor Q18

when the ACCESS pushbutton is depressed or the release timer is on, or the latch circuit is on etc. This is accomplished by applying a logic 0 from the various circuits to resistor R53. This provides base drive for transistor Q19 and causing it to conduct. This essentially shorts out transistor Q18. Diode CR28 serves two functions. First, diode CR37 conducts when transistor Q19 conducts, to maintain the 600 ohm termination on hybrid transformer T1. Second, with diode CR37 conducting it prevents a reversal of the polarity across capacitor C11 when: inhibit transistor Q19 conducts. The output of voice gate transistor Q18 is impressed across the primary winding of send transformer T1. Therefore, speech coming in on the two-wire port of the hybrid is inductively coupled to the voice gate transistor, amplified and inductively coupled out on the four-wire send pair via the secondary of the send transformer T1. The send transformer T1 is a 2:1 step down transformer. The 600 ohm impedance (looking in on the four-wire send pair) is controlled by resistor R50. The diodes across the four-wire send and receive ports provide lightning protection and clipping when the amplitude of the signals, appearing on these ports exceeds approximately 2 volts peak. The two-wire port is terminated in a 600 ohm resistor when the operator is not in on the call. The four-wire receive and send ports are terminated by the 600 ohm impedance presented by the automatic switching center.

Figure 5. Converter, Telephone Signal CV-1919/G, schematic diagram

(Located in back of manual)

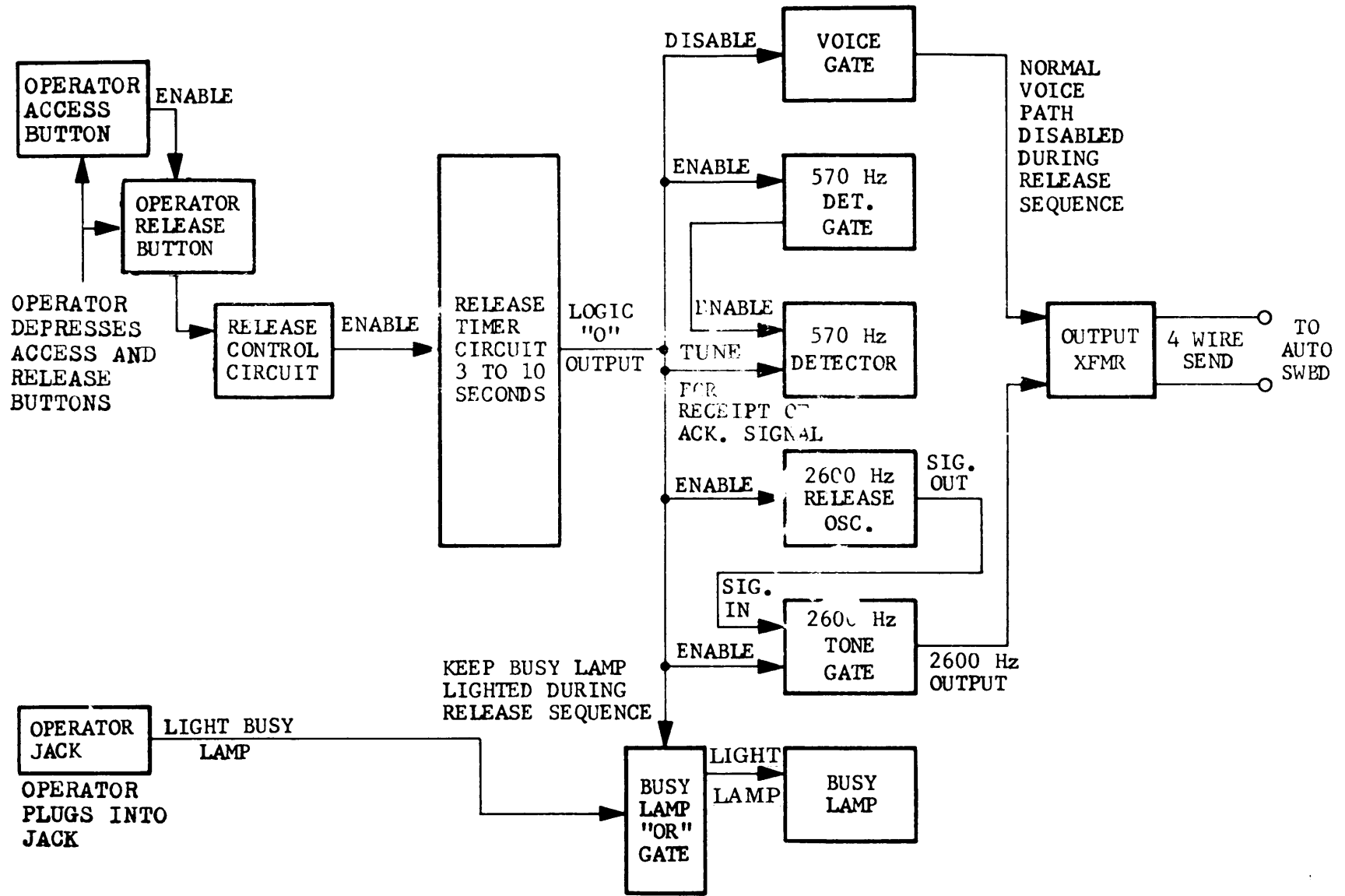

Figure 6. Converter, Telephone Signal CV-1919/G, Release Sequence Functional Block Diagram

## CHAPTER IV MAINTENANCE

---

### 11.0. Scope

Maintenance instructions provided in this chapter are for organizational-field maintenance only. The procedures that follow apply to the Converter, Telephone Signal CV-1919/G, regardless of its location. Restrictions are imposed only by the immediate circumstances involved, the availability of spare parts, tools, test equipment and the skill of the maintenance technicians. The printed wiring card and digit keysender, are not considered to be organizational field maintenance items. They are direct replacement assemblies which must be forwarded to a depot or the manufacturer for overhaul or replacement.

The organizational-field maintenance of the converter consists of the following:

- a. Visual inspection (paragraph 11.4)
- b. Troubleshooting procedures (paragraph 11.10)
- c. Component replacement (paragraphs 13.0 through 13.12)

### 11.1. Tools, Replaceable Parts, and Test Equipment Required to Perform Maintenance procedures

- a. Screwdriver, Flat Tip (medium size)
- b. Screwdriver, Cross-Recessed (medium size)
- c. Needle Nose Pliers
- d. Flat Nose Pliers
- Cutters or Wire Strippers
- Alignment Tool

### 11.2. Replaceable Parts

*NEC Part Nr.*

- a. Common Circuit Module Assembly
- b. Channel Circuit Module Assembly
- c. Combination Case Front Cover
- d. Combination Case Rear Cover
- e. Batteries - four D-size battery cells

### 11.3 Test Equipment

*NEC Part Nr.*

- a. Multimeter (TS-352D/U or equivalent)
- b. Test Cable (2)

#### 11.4 Visual Inspection

Before conducting any extensive troubleshooting, visually check the Converter for obvious faults. This will save repair time and can also avoid further damage to the Converter. Inspect the items listed

below for obvious defects; such as broken wires, loose connections, or other physical damage.

- a. Digit keysender
- b. SEIZE, RELEASE and ACCESS pushbuttons
- c. Binding posts for field wire terminations
- d. Night alarm
- e. Connectors on back of channel and common circuit modules
- f. Battery compartment

### 11.5 Seating

Check for proper seating (good connection) of Channel Modules and Common Circuit Modules to the mating connectors in the combination case. (See Section II on component replacement.)

#### 11.6 Wire Terminations

Check the field wire terminations on the back of the Converter (back cover removed).

#### 11.7 Wiring

Check the wiring between all switches and assemblies.

#### 11.8 Contacts

Check all switch and telephone jack contacts for obvious physical defects.

#### 11.9 Batteries

Check battery connections.

#### 11.10 Troubleshooting Procedure

11.10.1 General. Conduct the tests called out in Chapter 11, paragraphs 4, 6 and 7 to isolate the failure to the Converter. Refer to the troubleshooting chart (paragraph 12.0 below) for typical trouble symptoms.

11.10.2 Should the keysender or telephone jacks appear to be damaged and/or to require adjustment, refer to paragraphs 10.12 or 10.18.2 respectively.

11.10.3 Faulty Component Parts. Remove the faulty component part and replace it with one known to be operative, using the procedure given in paragraph 13 below.

11.10.4 Using the multimeter check to assure that the batteries are in peak condition. Check the battery voltage at the external battery binding posts located on the back of the unit (see Figure 2). Be careful to use proper polarity. Battery voltage should be 4.4 volts minimum. Reference Chapter II, paragraph 3 for information concerning the installation of battery cells and replace with fresh ones if necessary. Check the installation of the batteries for proper polarity.

**12.0. Troubleshooting Chart**

Before using the following chart, perform the checks

described in Chapter IV, paragraphs 11.4 through 11.10 above.

Symptom	Probable cause	Corrective action
(1) Cannot contact the switching center by depressing the SEIZE pushbutton and channel ACCESS pushbutton	No seize tone being transmitted by the Converter	Attempt to send seize tone from a different channel. If OK, replace defective channel module. Check field side terminations on binding posts (on back of the unit). Check wiring on seize switch.
(2) Cannot release from the Converter to the switching center	No release tone being transmitted by the Converter	Attempt to send release from a different Channel. If OK, replace the defective channel module. If not OK, check wiring to release switch. Check battery connection. If still bad, replace the common module.
(3) Servicing request indicator (SRI) doesn't function on one particular channel. Night alarm (N/A) does not indicate request-for-service.	Possible bad latch circuit Borken wire to SRI and N/A	Replace defective channel module Check wiring to the SRI and N/A
(4) Cannot break dial tone when dialing digits	Possible faulty keysender  Possible broken wire to channel ACCESS switch  Possible faulty DTMF tone gate Possible faulty DTMF oscillator circuit	Replace keysender (Refer to paragraph 13.0). Check wiring to ACCESS switch. Try different channel. If OK, replace common module. Replace defective channel module. Replace defective common module.
(5) Cannot cancel SRI or N/A by depressing ACCESS pushbutton for a particular channel	Possible faulty latch circuit	Replace defective channel module
(6) 570 Hz acknowledge tone is still heard in headset after ACCESS pushbutton is depressed	ACCESS pushbutton not clearing latch Faulty latch circuit Faulty ACCESS switch	Replace defective channel module Replace defective channel module Replace defective channel module
(7) Operator unable to talk to four-wire subscriber. Can hear four-wire subscriber	Faulty connection on two-wire port Bad connection on jacks in channel module Defective receiver Voice gate circuit defective	Check wiring Replace defective module Replace headset Replace defective channel module
(8) Switching Center cannot hear ringback tone from the Converter	Defective interrupter circuit Defective 425 Hz oscillator Defective tone gate Poor connection on field side termination	Replace common module Replace common module Replace common module Check wires on binding posts for defective channels

**13.0 Common Module Removal and Keysender Adjustment Information**

13.1 The DTMF oscillator printed wiring board is attached to the keysender. If adjustment of the keysender contacts is necessary, the printed wiring board will have to be removed from the keysender to gain access to the keysender contacts. The keysender is an integral part of the common module within the CV-1919. The following procedures should be followed when disassembling the keysender from the common module.

13.1.1 Remove the screws holding the common module to the Converter case (figs. 8 and 9).

13.1.2 Slide the common module out of the Converter by grasping the handle on the front of the

common module and pulling forward until the module has been completely extracted from the Converter case.

13.1.3 Remove the screws from the printed wiring board securing the board to the module case.

13.1.4 Swing the hinged printed circuit board away from the module to expose the internal circuitry.

13.1.5 Carefully remove the six screws securing the cover to the opposite side of the module.

13.1.6 Remove the two keysender brackets by removing the three screws securing the bracket to the keysender and battery case housing (on each side).

13.1.7 The keysender is now free and can be removed by sliding it back out of the front panel of the module.



13.1.8 Remove the screws securing the DTMF printed wiring board to the keysender (fig. 13).

13.1.9 Carefully remove the printed wiring board and lay to one side. The printed wiring board is wired to the keysender, but the lead length of the wires allow removal of the board from the keysender far enough to allow adjustment of the keysender contacts without unsoldering of wires (refer to Figure 9).

13.1.10 Carefully slide the keysender out of the module, through the opening in the side of the module.

13.1.11 The rest of the components in the common module, such as the night alarm, release and seize switches, etc., can also be removed for maintenance purposes by removing the screws from the common circuit wiring board and swinging it back as defined in step 13.1.3 above.

13.1.12 After the keysender has been removed it can be adjusted for proper spring tension etc. utilizing the following information.

**CAUTION**

When handling the keysender, extreme care must be taken not to grasp the keysender in such a manner that the fingers touch the spring pile-ups. Grasping by the spring pile-ups will upset their adjustment.

13.2 Sequence of Operation. When any keysender pushbutton is operated, the associated tone springs must make contact prior to make or break functions of the off manual switch combinations. Adjust by loosening the adjustment screw and properly positioning the common switch assembly on the mounting plate.

13.3 Tone Switch Adjustment Criteria

13.3.1 All bifurcated (dual) tone springs must rest against their plastic stops with a minimum of 10 grams.

13.3.2 All solid tone springs must rest against their associated crank arms with a minimum pressure of 10 grams.

13.3.3 In the non-operated condition there must be a minimum clearance of 1/32 inch between associated tone springs.

13.3.4 When operating, a tone-spring combination must make with a minimum follow of 1/32 inch.

13.3.5 Pushbutton and tone-spring association is as follows. See Figure 10 for orientation of tone-spring combinations.

Pushbutton	Tone-spring Pile-ups Operated
1	KS- 1 and -4
2	KS-2 and -4
3	KS-3 and -4
4	KS-1 and -5
5	KS-2 and -5
6	KS-3 and -5
7	KS-1 and -6
8	KS-2 and -6

Pushbutton	Tone-Spring Pile-Ups Operated
9	KS-3 and -6
0	KS-2 and -7
R	KS-1 and -7
C	KS-3 and -7

13.4 Common Switch Adjustment Criteria

13.4.1 In the unoperated condition the actuating slide must be held against its stop by the tension spring. The tension spring must be the only spring exerting a force against the slide. Other springs may be in contact with, but not exert sufficient force to cause the slide to move away from its stop.

13.4.2 In the unoperated position, each combination must be made with a minimum contact pressure of 10 grams.

13.4.3 In the fully operated position each combination must be opened with a minimum contact separation of 0.010 inch.

13.5 Common Module Subassembly Removal Procedures

The following procedures should be utilized when removal of the various subassemblies in the common module is necessary. In all subassembly removal procedures, the batteries must be removed prior to removal of the subassemblies.

13.5.1 Night Alarm Removal

Repeat steps 13.0 through 13.1.1 above to allow exposure of the night alarm unit inside the common module.

a. The night alarm unit is not keyed and is held into place by the knurled ring on the front panel.

b. Firmly grasp the body of the night alarm unit inside the common module to keep it from turning and unscrew the knurled ring from the front panel.

c. Remove the night alarm unit from the panel by pulling it back out of the front panel.

d. Remove the two screws securing the wires to the night alarm unit.

e. To replace the night alarm unit, reverse the above procedures.

**NOTE**

When removing and replacing the wires on the night alarm unit, polarity of the connection is important and must be observed to prevent damage to the unit.

13.6 Seize and Release Switch Removal and Replacement Procedures (fig. 14)

a. Remove screws securing the common circuit printed wiring board to the common module frame.

b. Swing hinged board out to expose the internal circuitry.

c. Remove the hex nut the from panel used to secure the seize or release switch to the front panel.

d. Remove the switch from the front panel by taking it out of the module from the inside.

e. Unsolder the wires attached to the switch. Wires should be tagged for proper identification during reinstallation.

f. To install replacement switch, reverse procedures a through e above.

### 13.7 Power On-Off Switch Removal and Replacement Procedures (fig. 16)

a. Repeat steps a and b, paragraph 13.6 above.

b. Remove the hex nut and washers securing the power on-off switch to the front panel.

c. Remove the switch from the rear of the front panel.

d. Unsolder the wires. Tag wires for proper identification during reinstallation.

e. Reverse procedures of steps a through d above to install replacement switch.

### 13.8 Channel Module Removal and Replacement Procedures (fig. 7)

a. Remove the screws on the front panel securing the channel module to the combination case.

b. Pull out on the handle on the front of the module being removed until the module is completely free of case.

c. Reverse above procedures for installing new module.

### 13.9 Channel Module Subassemblies Removal and Replacement (fig. 7)

#### NOTE

To gain access to the subassemblies contained in the channel module, the module must first be removed from the combination case. (Refer to paragraph 13.3.) The screws securing "the printed wiring board to the module frame must be removed and the hinged PWB swung outward to expose the internal circuitry of the module. In some instances, the side cover plate may have to be removed (by removing the screws securing it to the module frame).

#### 13.9.1 Service Request Indicator Removal and Replacement Procedures

a. Remove the two screws securing the service request indicator to the front panel of the channel module.

b. Remove the service request indicator from the back of the front panel. Be careful not to loosen the flange on the front of the front panel. This flange is used to secure the service request indicator to the front panel.

c. Unsolder the wires on the service request indicator. Tag wires as they are removed to assure proper terminations when installing the replacement unit.

d. Reverse procedures of steps a through c to install replacement unit.

#### 13.9.2 Telephone Jack Removal and Replacement Procedures (figs. 7 and 17)

a. Remove the hex nuts securing the telephone jacks to the front panel of the channel module.

b. Remove both jacks through the side of the module. Be extremely careful not to break any of the wires attached to the jacks.

c. Unsolder and tag the wires from the jack being replaced to insure proper termination of the wires when installing the replacement unit.

d. Reverse the procedures in steps a through c above to install the replacement unit.

### 13.10 Channel Circuit Printed Wiring Board Removal and Replacement Procedures (figs. 7 and 11)

a. Unsolder and tag all the wires attached to the printed wiring board.

b. Remove the two screws securing the printed wiring board to the hinge.

c. Reverse the above procedure for installation of replacement unit.

### 13.11 Access Switch Removal and Replacement Procedures (figs. 7 and 18)

a. Remove the hex nut securing the access switch to the front panel.

b. Remove the access switch from the front panel through the side of the module.

c. Unsolder and tag all the wires on the access switch to insure proper termination of the wires on the replacement switch.

d. Reverse the procedures in steps a through c above for installation of replacement unit.

### 13.12 Disassembly Procedures for Lightning Arrestor Enclosure (figs. 3 and 15)

a. Access to the lightning arrestors and internal connections to the binding posts is obtained by turning the quarter turn fasteners  $\frac{1}{4}$  of a turn counter-clockwise. These fasteners secure the lightning arrestor cover to the case. Care should be taken when removing the cover so as not to tear the cover gasket. If the gasket is damaged during the removal of the cover, replace with a new gasket before reinstalling the cover.

b. The lightning arrestors have bayonette type sockets and can be removed by turning the arrestor counter-clockwise approximately one quarter of a turn and pulling out. To install a replacement arrestor, reverse this procedure.

c. To replace a damaged binding post, unsolder the wire attached to the binding post and remove the hex nut securing the post to the enclosure and remove the binding post. Reverse this procedure for installation of a replacement binding post.

d. When repairs have been completed, replace the arrestor enclosure cover being extremely careful to

insure proper placement of the gasket to insure that the enclosure remains waterproof.

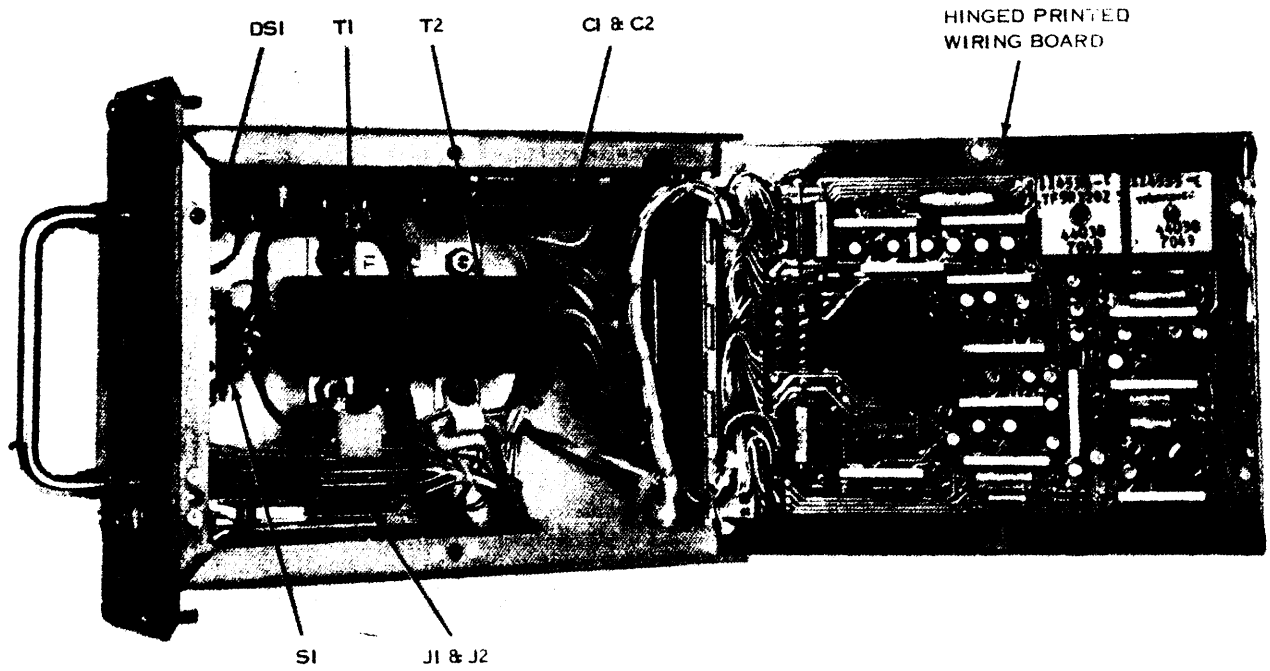

EL20B004

Figure 7. Converter, telephone signal CV-1919/G, Channel module (CN-1667), circuitry exposed.

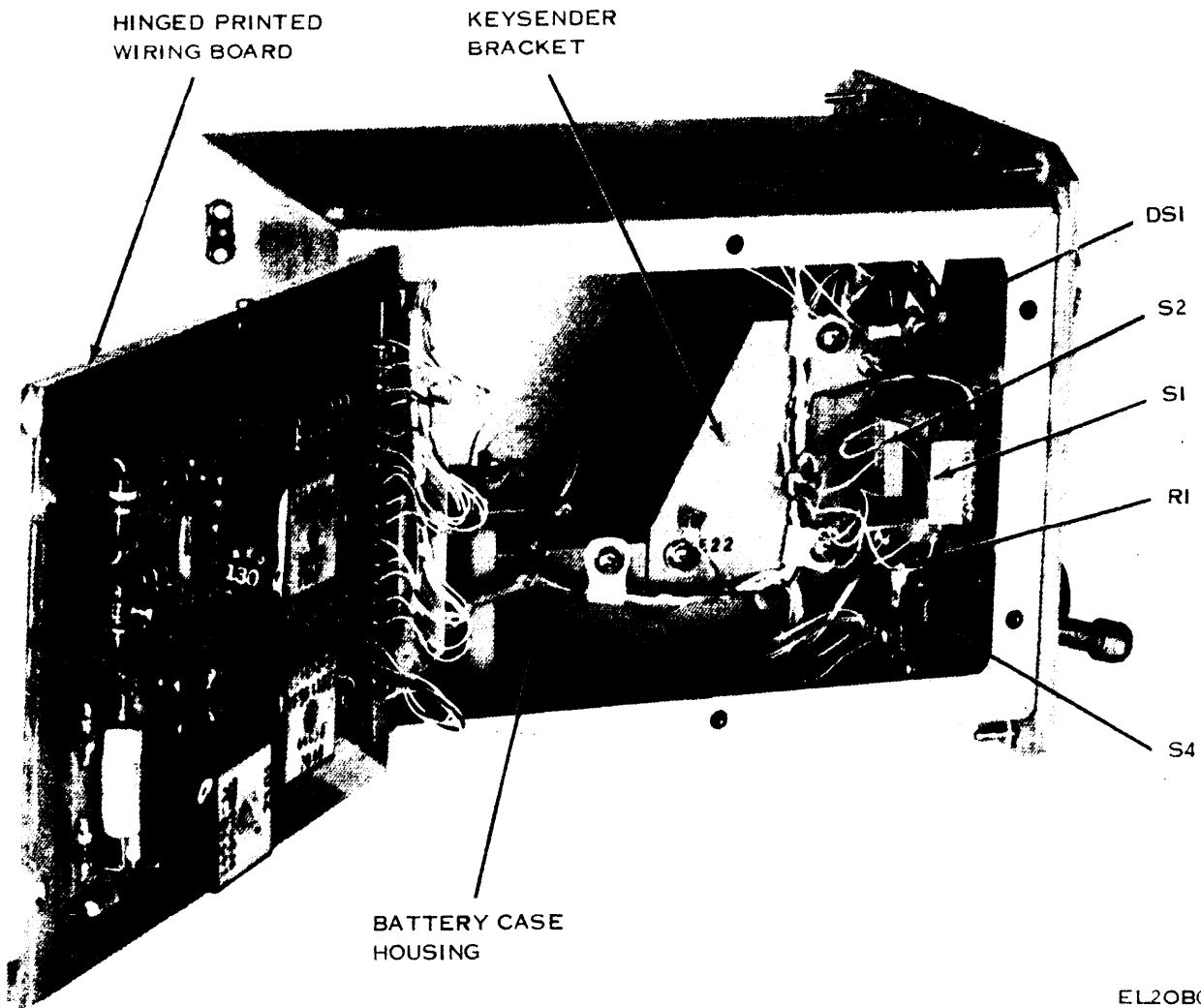

EL20B005

Figure 8. Converter, telephone signal CV-1919/G, Common module (CN-1668), circuitry exposed.

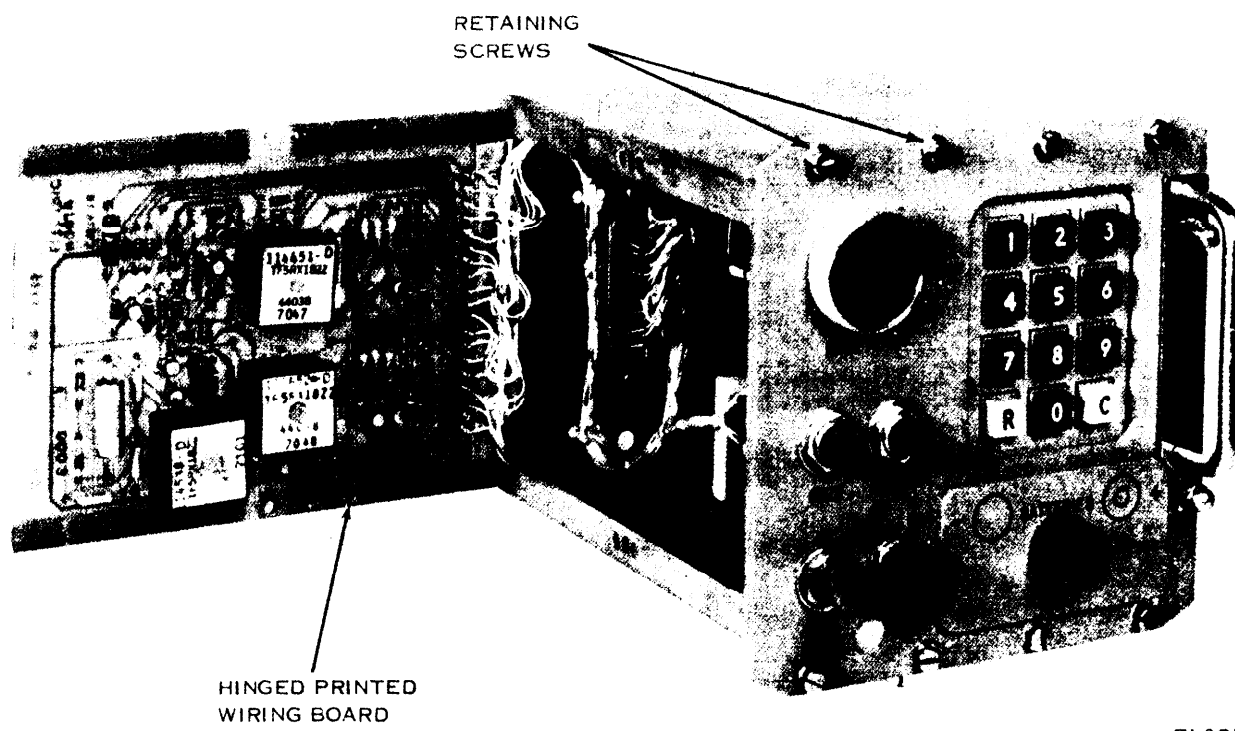

EL20B006

Figure 9. Converter, telephone signal CV-1919/G, Common module (CN-1668), PWB circuitry exposed.

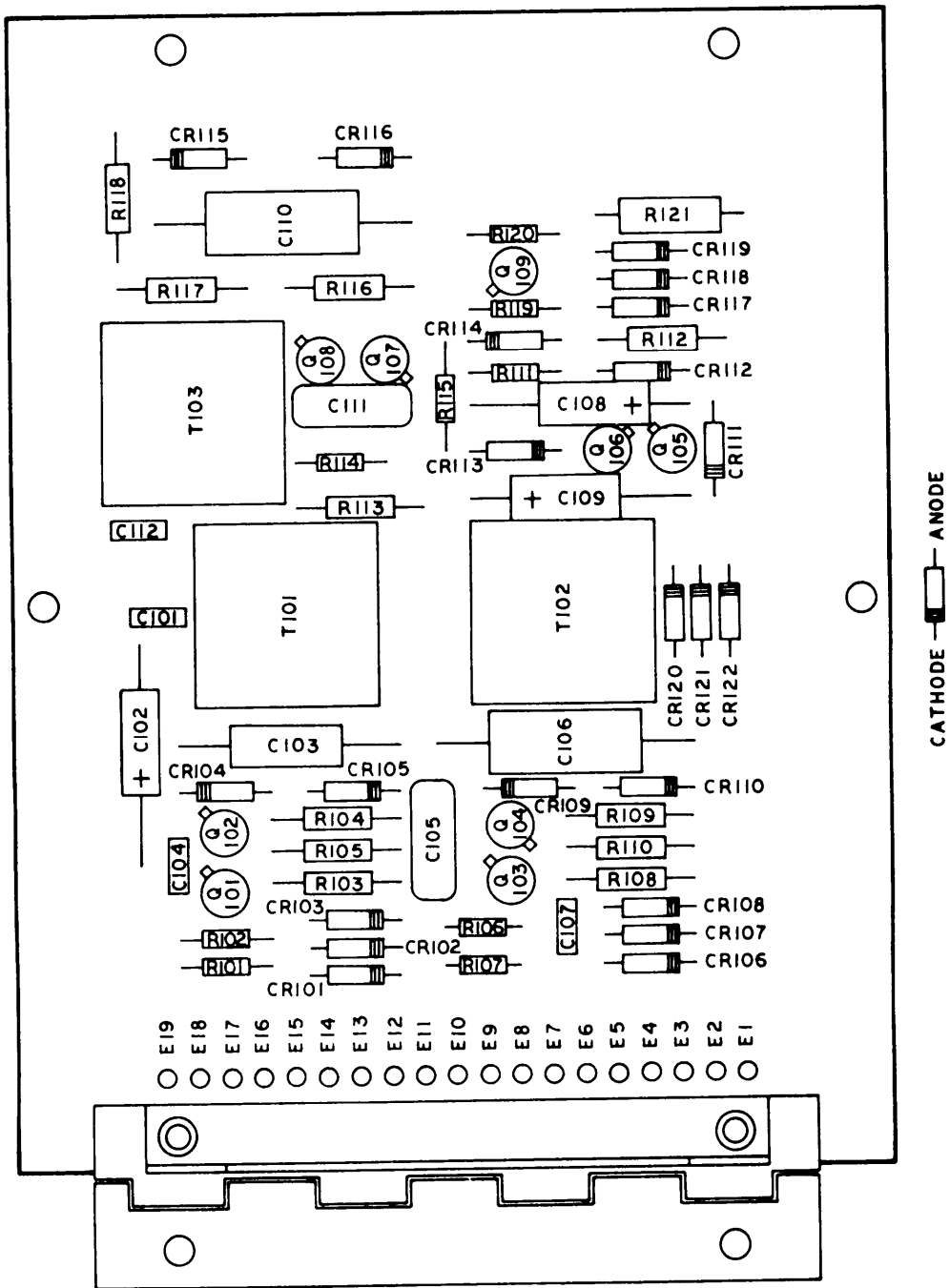
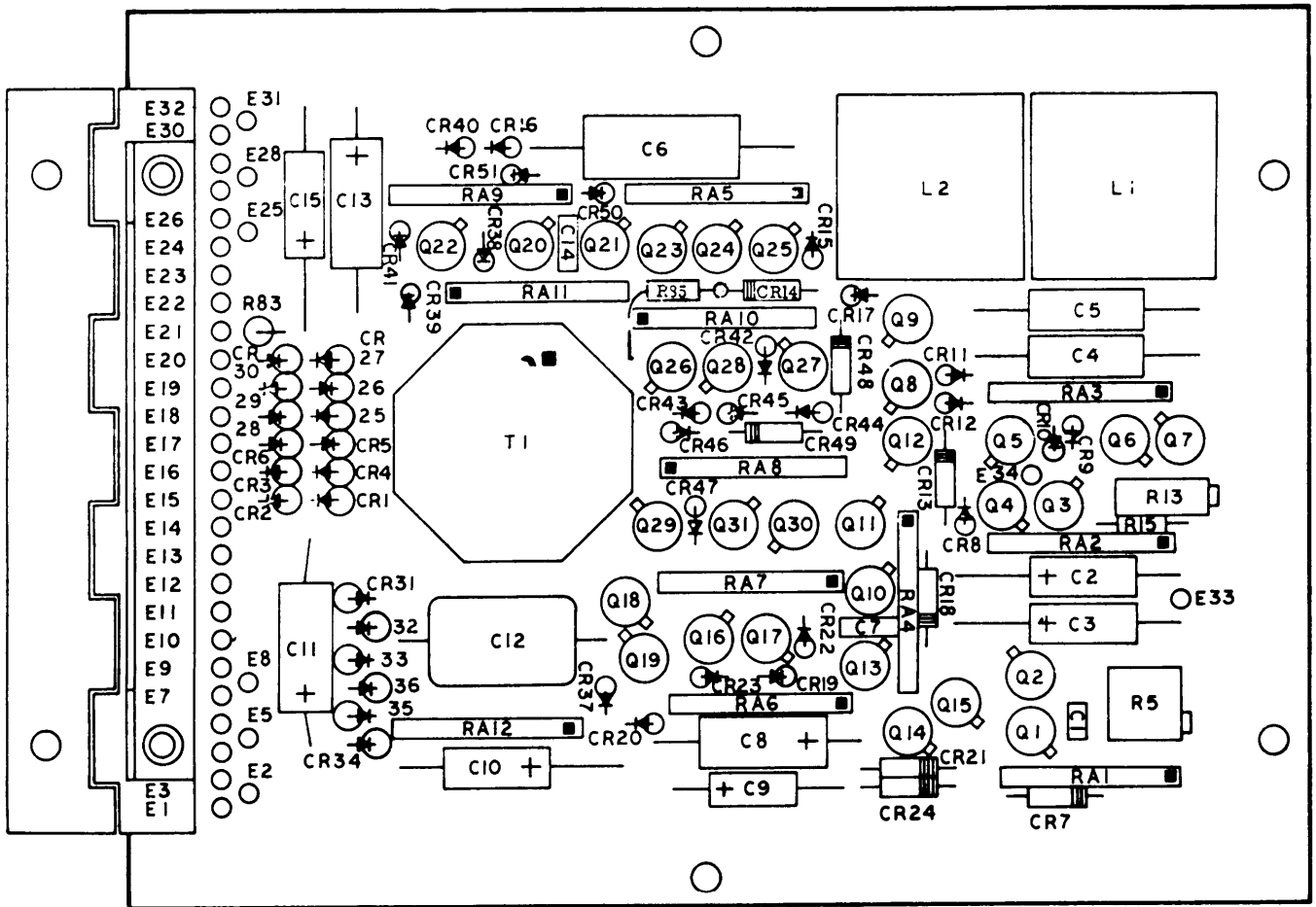

Figure 10. Converter, Telephone Signal CV-1919/G, Common Circuit PWB Assembly (CN-1638).



■ DENOTES PIN 1

CATHODE  ANODE

NOTE: REFERENCE DESIGNATORS RA1 THROUGH RA12 ARE THICK FILM NETWORKS. REFER TO THICK FILM SCHEMATICS FOR RESISTOR BREAKOUTS.

Figure 11. Converter, Telephone Signal CV-1919/G, Channel PWB Assembly (CN-1643).

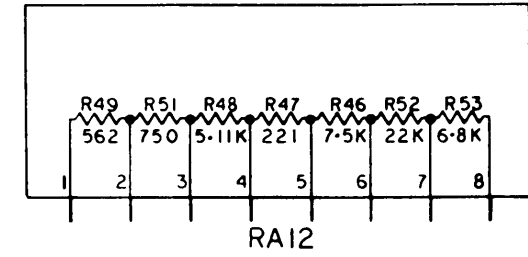
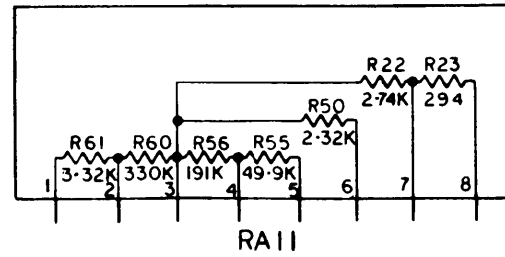
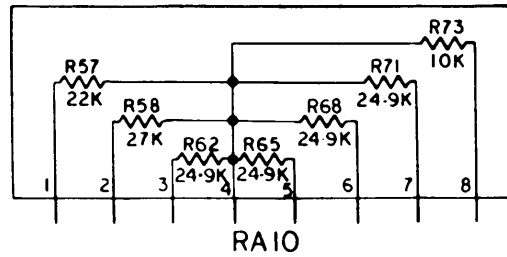
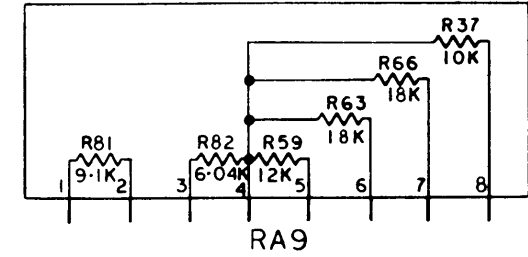
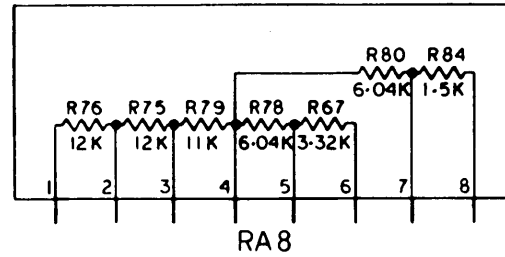
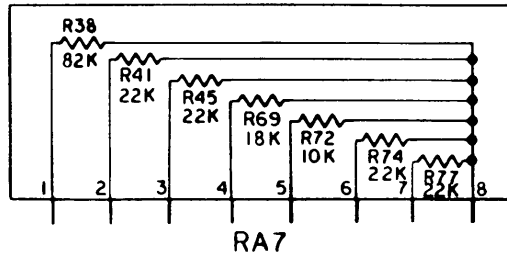
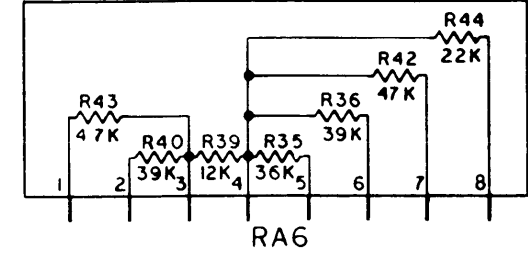
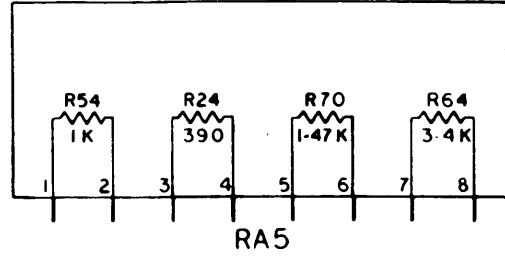
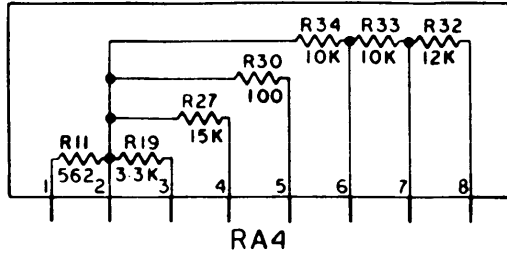
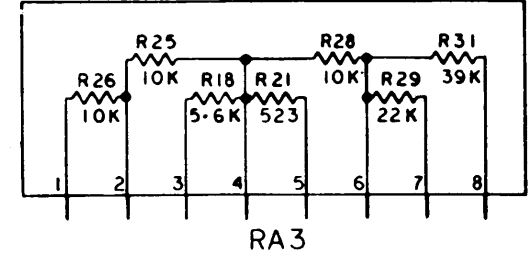
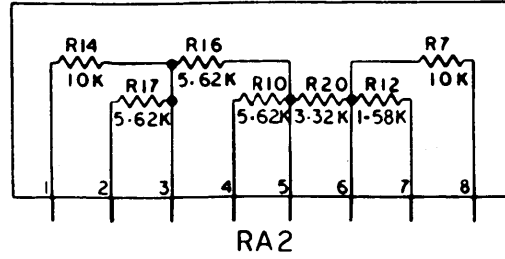
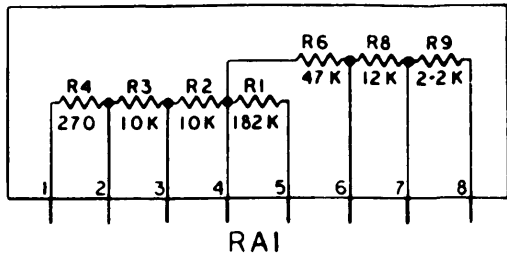

Figure 12. Thick Film Network Schematics (RA1-RA12)



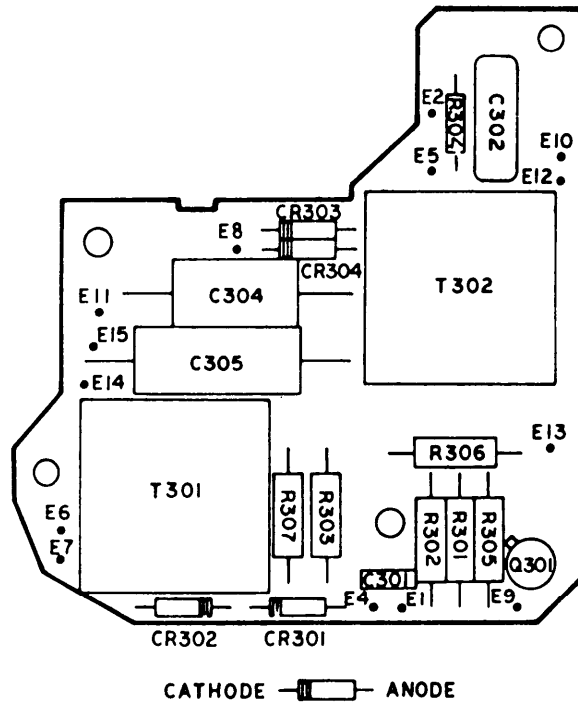

Figure 13. DTMF Oscillator PWB Assembly (common module)

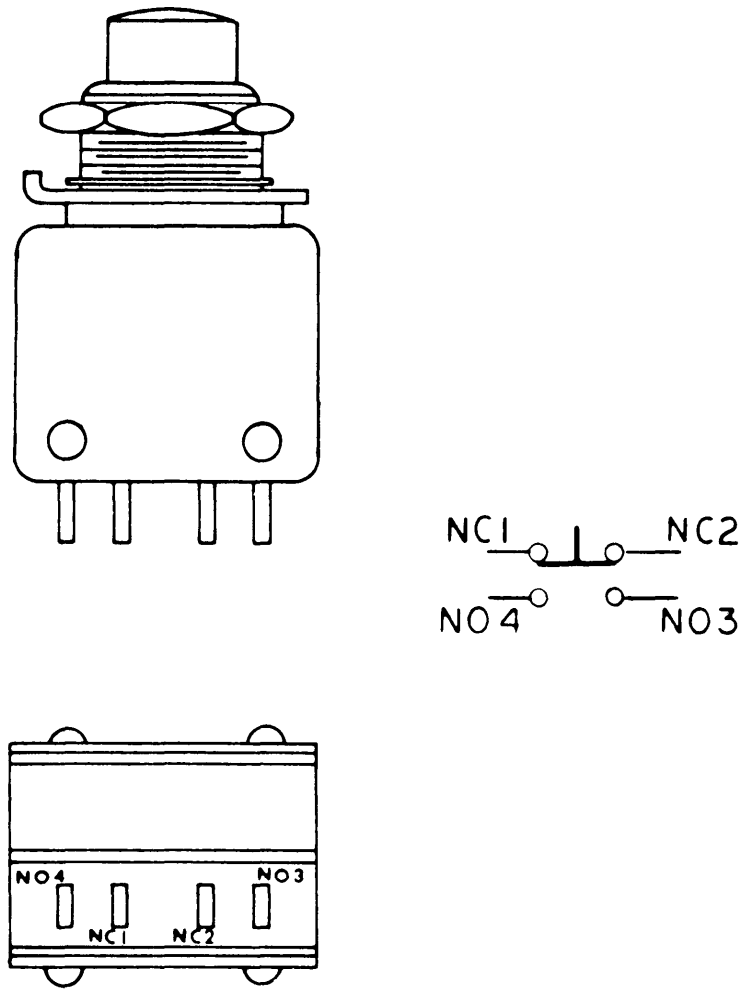

Figure 14. RELEASE Switch, S2 (common module)

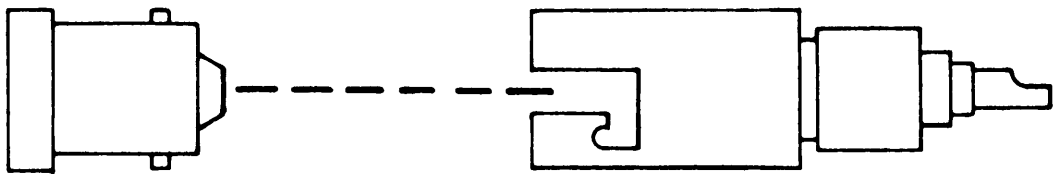
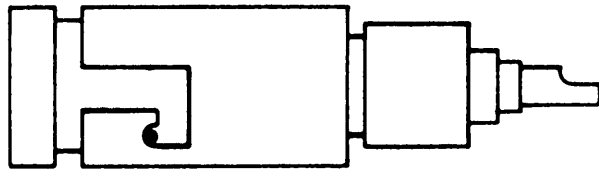

Figure 15. Lightning Arrestor

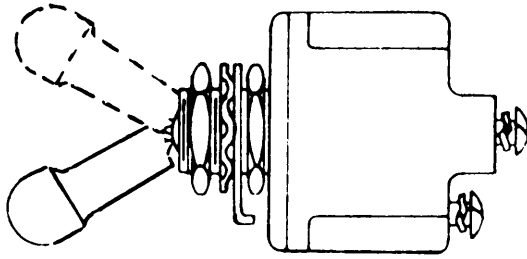

Figure 16. POWER ON-OFF Switch, S4 (common module)

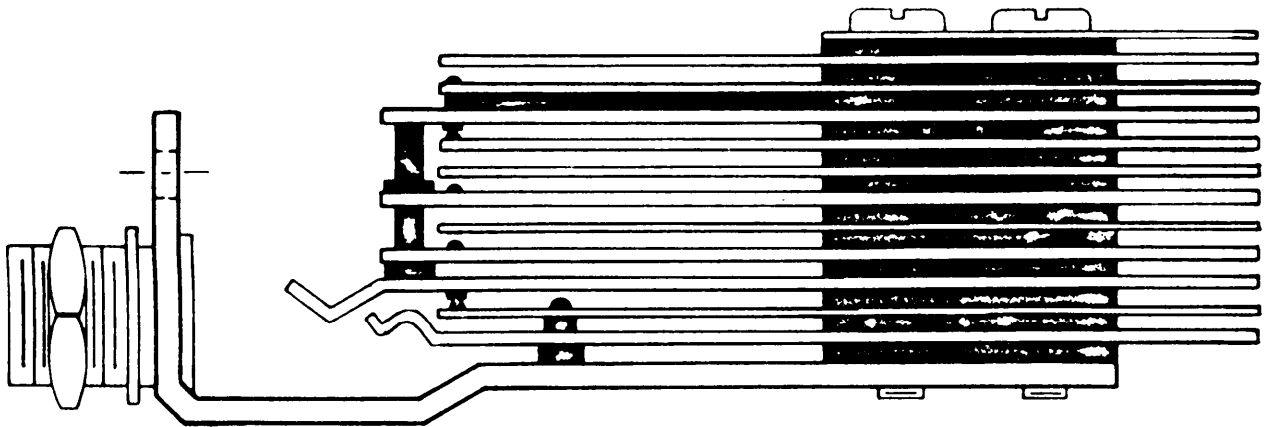
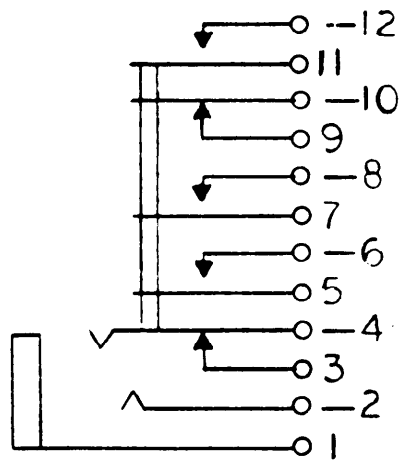

Figure 17. Telephone Jack (J1, J2)

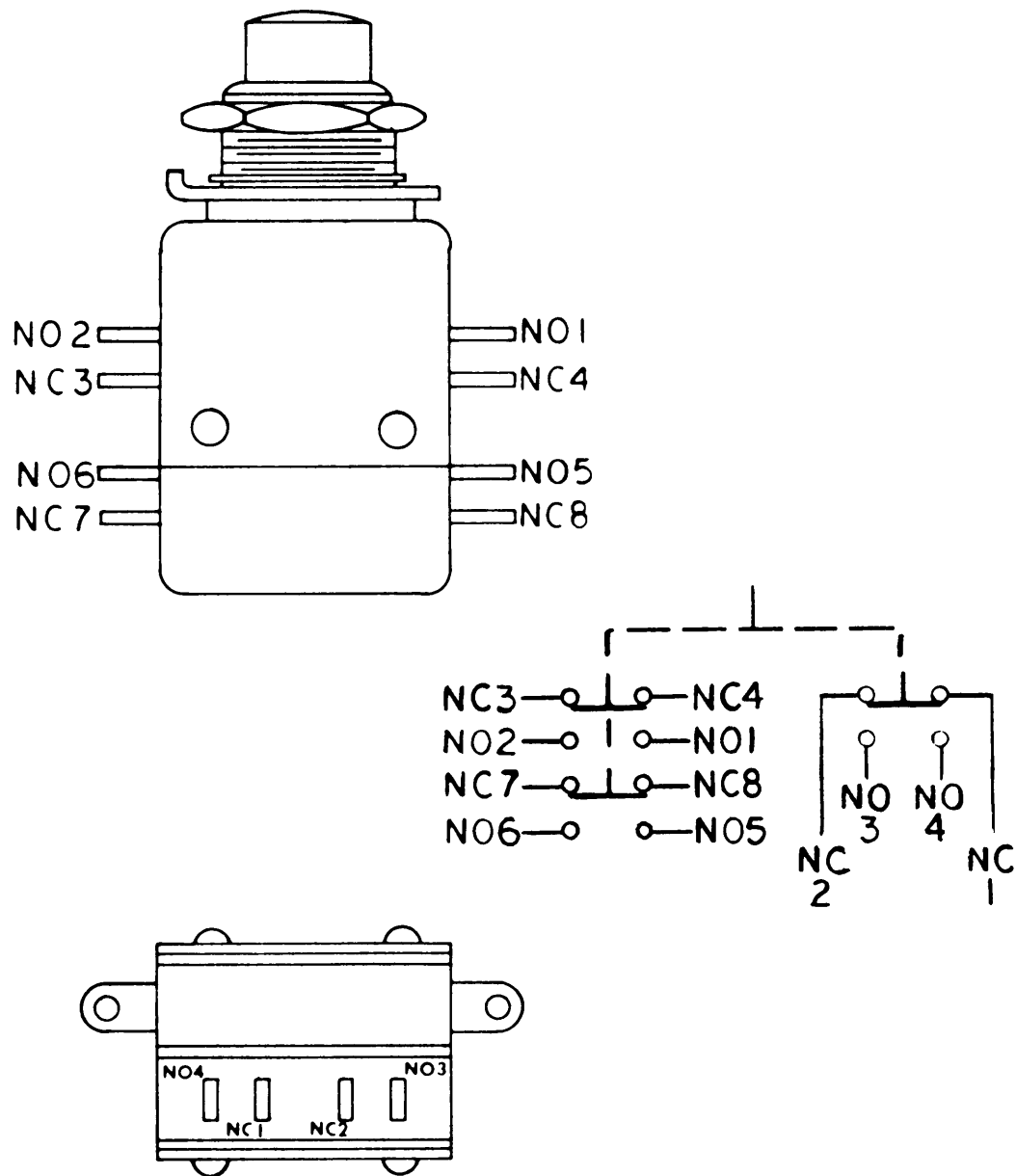

Figure 18. SEIZE switch, S1 (common module) and ACCESS switch, S1 (channel module)



## APPENDIX A REFERENCES

---

DA Pam 310-4	Index of Technical Manuals, Technical Bulletins, Supply Manuals (types 7, 8, and 9), Supply Bulletins, and Lubrication Orders.
DA Pam 310-7	US Army Equipment Index of Modification Work Orders.
SB 11-573	Painting and Preservation Supplies Available for Field Use for Electronics Command Equipment.
SB 700-20	Army Adopted/Other Items Selected for Authorization/List of Reportable Items.
TB 43-0118	Field Instructions for Painting and Preserving Electronics Command Equipment including camouflage pattern painting of electrical equipment shelters.
TM 11-2134	Manual Telephone Switchboard SB-86/P: Installation and Operation.
TM 11-5805-262-12	Operators and Organizational Maintenance Manual: Switchboards, Telephone, Manual SB-22/PT and SB-22A/PT.
TM 11-5805-628-12	Operator's and Organizational Maintenance Manual: Automatic Telephone Central Offices AN/TTC-38(V)1 and AN/TTC-38(V)2.
TM 38-750	The Army Maintenance Management System (TAMMS).
TM 740-90-1	Administrative Storage of Equipment.
TM 750-244-2	Procedures for Destruction of Electronics Materiel to Prevent Enemy Use (Electronics Command).
TM 11-6625-366-15	Operator's Organizational, DS, GS, and Depot Maintenance Manual Multimeter TS-352B/U.





## APPENDIX B MAINTENANCE ALLOCATION

---

### Section I. INTRODUCTION

#### B-1. General

This appendix provides a summary of the maintenance operations for CV-1919/G. It authorizes categories of maintenance for specific maintenance functions on repairable items and components and the tools and equipment required to perform each function. This appendix may be used as an aid in planning maintenance operations.

#### B-2. Maintenance Function

Maintenance functions will be limited to and defined as follows:

*a. Inspect.* To determine the serviceability of an item by comparing its physical, mechanical, and/or electrical characteristics with established standards through examination.

*b. Test.* To verify serviceability and to detect incipient failure by measuring the mechanical or electrical characteristics of an item and comparing those characteristics with prescribed standards.

*c. Service.* Operations required periodically to keep an item in proper operating condition, i.e., to clean, preserve, drain, paint, or to replenish fuel/lubricants/hydraulic fluids or compressed air supplies.

*d. Adjust. Maintain* within prescribed limits by bringing into proper or exact position, or by setting the operating characteristics to the specified parameters.

*e. Align.* To adjust specified variable elements of an item to about optimum or desired performance.

*f. Calibrate.* To determine and cause corrections to be made or to be adjusted on instruments or test measuring and diagnostic equipment used in precision measurement. Consists of the comparison of two instruments, one of which is a certified standard of known accuracy, to detect and adjust any discrepancy in the accuracy of the instrument being compared.

*g. Install.* The act of emplacing, seating, or fixing into position an item, part, module (component or assembly) in a manner to allow the proper functioning of the equipment/system.

*h. Replace.* The act of substituting a serviceable like-type part, subassembly, model (component or assembly) for an unserviceable counterpart.

*i. Repair.* The application of maintenance ser-

vices (inspect, test, service, adjust, align, calibrate, replace) or other maintenance actions (welding, grinding, riveting, straightening, facing, remachining, or resurfacing) to restore serviceability to an item by correcting specific damage, fault, malfunction, or failure in a part, subassembly, module/component /assembly, end item or system. This function does not include the trial and error replacement of running spare type items such as fuses, lamps, or electron tubes.

*j. Overhaul.* That periodic maintenance effort (service/action) necessary to restore an item to a completely serviceable/operational condition as prescribed by maintenance standards (e.g., DMWR) in appropriate technical publications. Overhaul is normally the highest degree of maintenance performed by the Army. Overhaul does not normally return an item to like-new condition.

*k. Rebuild.* Consists of those services/actions necessary for the restoration of unserviceable equipment to a like-new condition in accordance with original manufacturing standards. Rebuild is the highest degree of material maintenance applied to Army equipment. The rebuild operation includes the act of returning to zero those age measurements (hours, miles, etc.) considered in classifying Army equipment /components.

#### B-3. Column Entries

*a. Column 1, Group Number.* Column 1 lists group numbers, the purpose of which is to identify components, assemblies, subassemblies and modules with the next higher assembly.

*b. Column 2, Component/Assembly.* Column 2 contains the noun names of components, assemblies, subassemblies, and modules for which maintenance is authorized.

*c. Column 3, Maintenance Functions.* Column 3 lists the functions to be performed on the item listed in column 2. When items are listed without maintenance functions, it is solely for purpose of having the group numbers in the MAC and RPSTL coincide.

*d. Column 4, Maintenance Category.* column 4 specifies, by the listing of a "worktime" figure in the appropriate subcolumn(s), the lowest level of maintenance authorized to perform the function

listed in column 3. This figure represents the active time required to perform that maintenance function at the indicated category of maintenance. If the number or complexity of the tasks within the listed maintenance function vary at different maintenance categories, appropriate "worktime" figures will be shown for each category. The number of man-hours specified by the "work time" figure represents the average time required to restore an item (assembly, subassembly, component, module, end item or system) to a serviceable condition under typical field operating conditions. This time includes preparation time, troubleshooting time and quality assurance/quality control time in addition to the time required to perform the specific tasks identified for the maintenance functions authorized in the maintenance allocation chart. Subcolumns of column 4 are as follows:

- C - Operator/Crew
- O- Organizational
- F - Direct Support
- H - General Support
- D- Depot

e. *Column 5, Tools and Equipment.* Column 5 specifies by code, those common tool sets (not in-

dividual tools) and special tools, test, and support equipment required to perform the designated function.

**B4. Tool and Test Equipment Requirements (Table 1)**

a. *Tool or Test Equipment Reference Code.* The numbers in this column coincide with the numbers used in the tools and equipment column of the MAC. The numbers indicate the applicable tool or test equipment for the maintenance functions.

b. *Maintenance Category.* The codes in this column indicate the maintenance category allocated the tool or test equipment.

c. *Nomenclature.* This column lists the noun name and nomenclature of the tools and test equipment required to perform the maintenance functions.

d. *National/NATO Stock Number.* This column lists the National/NATO stock number of the specific tool or test equipment.

e. *Tool Number.* This column lists the manufacturer's part number of the tool followed by the Federal Supply Code for manufacturers (5-digit) in parentheses.

Section II Maintenance Allocation Chart For CV1919/G

(1) GROUP NUMBER	(2) COMPONENT/ ASSEMBLY	(3) MAINTENANCE FUNCTION	(4) MAINTENANCE CATEGORY					(5) TOOLS AND EQUIPMENT
			C	O	F	H	D	
00	Converter, Telephone Signal CV-1919/G	Inspect	0.1					
		Test		0.3				1
		Service		0.1				
		Install		0.5				2
		Repair'		0.3				1, 2
		Repair'			1.0			1, 2
		Overhaul				20.0		1, 2
01	Chassis	Repair			1.0			1, 2
02	Channel Module	Repair			1.0			1, 2
0201	Channel Module Circuit Card	Replace			0.5			2
		Repair				2.0		1, 2
03	Common Module	Repair			1.0			1, 2
0301	Common Module Circuit Card	Replace			1.0			2
		Repair				2.0		1, 2
0302	oscillator Assembly	Repair			1.0			1,2
0303	Keyset Assembly	Replace			0.5			2
		Adjust			1.0			2

1 By replacement of Batteries, common module, channel module, or lightning arrester.  
 2 By replacement of chassis mounted piece parts.

Tool and Test Equipment Requirements For CV-1919/G

TOOL OR TEST EQUIPMENT REF CODE	MAINTENANCE CATEGORY	NOMENCLATURE	NATIONAL/ NATO STOCK NUMBER	TOOL NUMBER
1	O, F, D	Multimeter TS-352B/U	6625-00- 553-0142	
2	O, F, D	Tool Kit, Electronic Equipment TK-105/G	5180-00- 610-8177	



By Order of the Secretary of the Army:

FRED C. WEYAND  
*General, United States Army*  
*Chief of Staff*

Official:

PAUL T. SMITH  
*Major General, United States Army*  
*The Adjutant General*

**DISTRIBUTION:**

*Active Army:*

USASA (2)	USAICS (3)
COE (1)	MAAG (1)
TSG (1)	USARMIS 1)
USAARENBD (1)	Installations (2) except
DARCOM (1)	Fort Carson (5)
TRADOC (2)	Fort Gillem (10)
OS Maj Comd (4)	Fort Gordon (10)
LOGCOMDS (3)	Fort Huachuca (10)
MICOM (2)	Ft Richardson (ECOM Ofc) (2)
TECOM (2)	LBAD (14)
USACC (4)	SAAD (30)
MDW (1)	TOAD (14)
Armies (2)	SHAD (3)
Corps (2)	SigFLDMS (1)
HISA (Ft Monmouth) (33)	USAERDAA (1)
Svc Colleges (1)	USAERDAW (1)
USASESS (5)	Units org under fol TOE: (1)
USAADS (2)	11-35
USAFAS (2)	29-16
USAARMS (2)	29-26
USAIS (2)	29-36
USAES (2)	29-134

NG: None

USAR: None

For explanation of abbreviations used see, AR 310-50



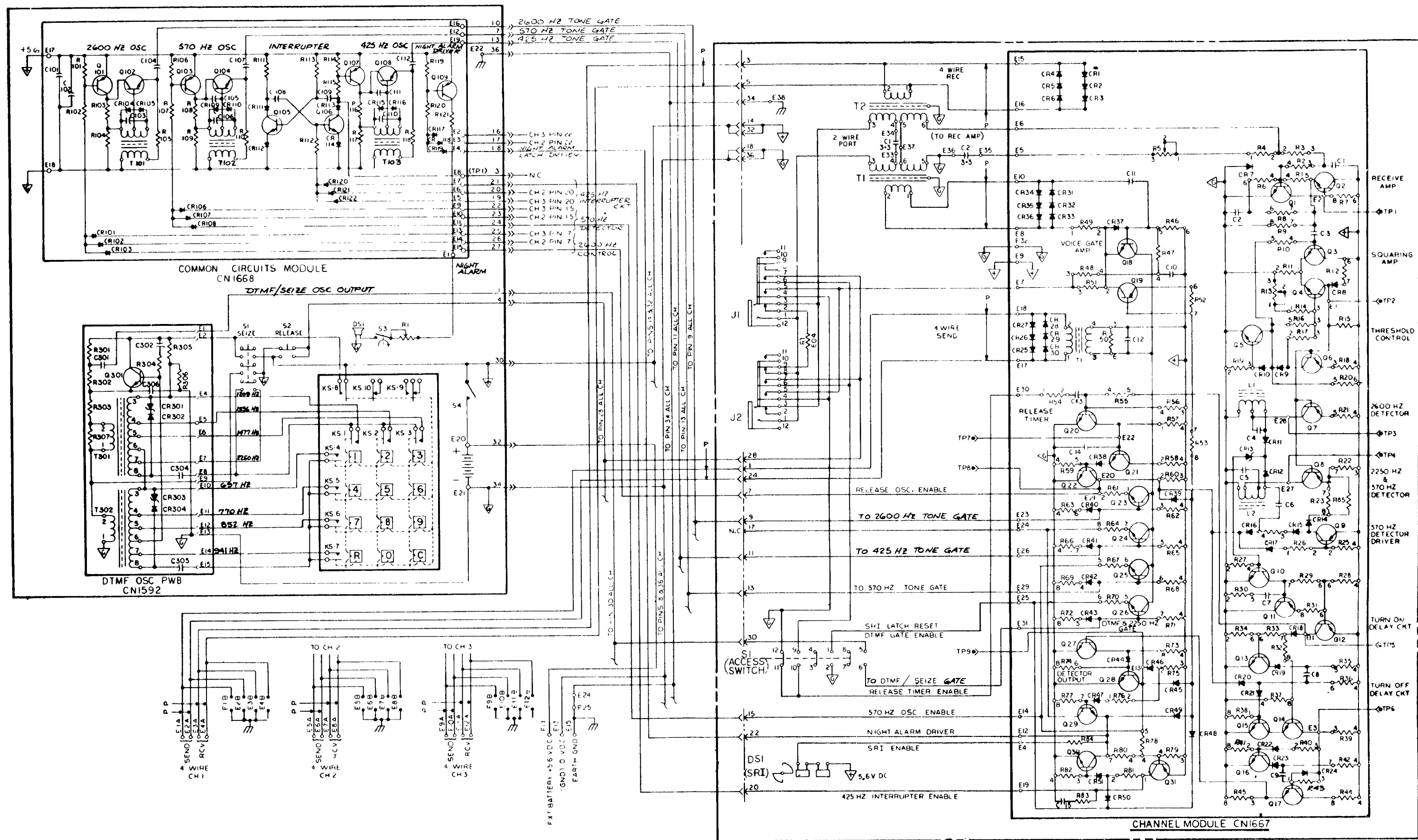

Figure 5. Converter, Telephone Signal CV-1919/G, schematic diagram.





**PIN: 015499-000**